

Project Name: _____	AIA # _____
Location: _____	SIS # _____
Item #: _____ Qty: _____	

Model: SM40X

HCFCs and CFCs Free

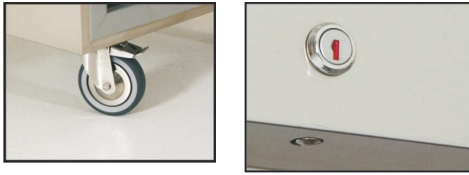

SM40X

Standard Features

- Electronic control
- Ventilated

- Compact refrigeration System
- Auto defrost

- Auto evaporation
- Gas R404a

- Poliurethane insulation 50mm CFC/HCFC free

- AISI 441 Grade Stainless Steel interior/exterior

- Interior rounded corner
- Adjustable plastic feet

- Adjustable inox feet on request
- Reversible doors
- Self closing doors on freezer models

- Plastic-coated shelves dim. 460x 485mm
- Push-fit magnetic door seal

- 1 Door

Optionals and Accessories

H.A.C.C.P control - Castors - Door lock - Stainless Steel shelves -Inox feet

ENVIRONMENTALLY FRIENDLY FEATURES

(CFC & HCFC free) R404A refrigerant.
 High-tech environmentally friendly CFC-HCFC free, Cyclopentane foaming, keeping insulation properties for longer.
 Lower energy consumption and less CO2 emissions.
 Made of almost 99% recyclable materials.
 * LED light versions will save from 50% to 75% of energy compared to classic bulbs.
 ISO 14001 Certified

	Temperature			
	A	B	C	D
°C	-2 +8			
°F				

Capacity	Voltage	Abs. Power		Unit Size	Packaging Size	Shelves	Ambient Temp.	Weight
Lt	Volt/Hz	HP	Amps	Watt	LxDxH cm	LxDxH cm	Nr.	°C
400	220-240/50Hz			270	600x600x1900	640x640x2050	3	+43
Cu.Ft	Volt/Hz	HP	Amps	Watt	LxDxH (inches)	LxDxH (inches)	Nr.	°F

	Approvals: _____	Available at: _____
--	------------------	---------------------

Project Name: _____	AIA # _____
Location: _____	
Item #: _____ Qty: _____	SIS # _____

Model: SM40X

HCFCs and CFCs Free

ARCHITECT CORNER

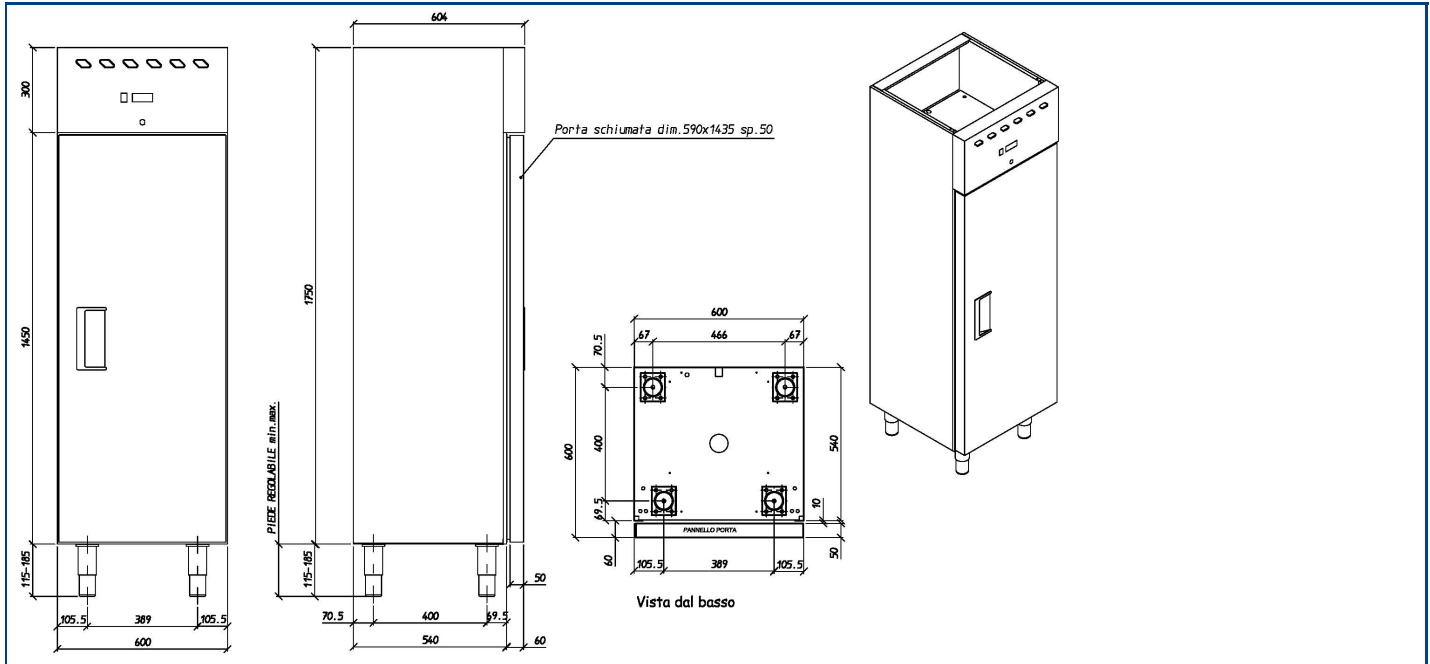

STANDARD FEATURES

DESIGN

Desmon reach-ins are manufactured in Italy with enduring ergonomic features to protect your long term investment. Designed using the highest technologies, quality materials and components to provide the user with colder product temperatures, lower utility costs, exceptional food safety and the best value in today's food service marketplace.

CABINET CONSTRUCTION

All made in stainless steel, not only on solid doors and front side as other manufacturers. The finest stainless available; latest generation, higher tensile strength for fewer dents and scratches. (External back & bottom in galvanized steel Aluminium inside on some Basic versions). Higher insulation rates thanks to high-tech environmentally friendly CFC free, Cyclopentane foaming keeping insulation properties longer than other foams. Panel thickness: Basic 50mm (2) Silver & Gold 60mm (2 1/2") and Platinum 75mm (3) - instead of average 2" on other brands. Internal Rounded Corners on all models.

Heavy duty galvanized frame rail for corrosion protection inside and out.

REFRIGERATION SYSTEM

Factory engineered, self-contained, capillary tube system using environmentally friendly (CFC free) R404A refrigerant. Thermostatic valve on Monoblock freezer versions. Evaporator coil & condenser balanced for low power consumption - holding the widest temperature range in its class: Temperature Range, getting the best in food preservation: Coolers adjustable from -2°C to +8°C (28°F to 46°F) - . Freezers adjustable from -10°C to -25°C. (14°F to -13°F) Sealed, cast iron, self-lubricating evaporator fan motor(s) and larger fan blades with a more efficient low velocity, high volume airflow design. Ensuring faster temperature recovery and shorter run times in the busiest of food service environments. Top mounted condensing unit easily accessible for maintenance. Engine's heat doesn't cause thermal dispersion into the cold-room.

DOORS

Stainless steel exterior and interior. Door extends full width of cabinet shell. Guaranteed door handle. Positive seal self-closing door. * Guaranteed door hinges and torsion type closure system. Magnetic door gasket of one piece construction, removable without tools for ease of cleaning.

SHELVING

GN 2/1 Version: Adjustable, heavy duty PVC coated wire - size: 530mm x 650mm (20 43/50" x 20 43/50 ") Pastry Version: Adjustable, heavy duty pan or shelf size 600mm x 400mm (23 5/8" x 15 3/4 ").

LIGHTING

Version with lights includes: LED lighting safety shielded. Lights activated by micro-switch mounted above door. Glass door LED lights available

MODEL FEATURES

Exterior adjustable temperature digital display with alarm and HACCP advanced control unit standard on every GOLD and PLATINUM model. Evaporator is epoxy coated to eliminate the potential of corrosion. ETL Sanitation and CE Rounded Corners compliant for open food product.

ELECTRICAL

Unit completely pre-wired at factory and ready for final connection to a dedicated outlet. Cord and plug set included: Voltages: 115V/60Hz/1 phase -15 /20 amp or 230V/50Hz/1 phase -16 amp or 230V/60 Hz 16 amp

WARRANTY

Two year warranty on parts

