

COMPRESSION SILENT BLOC: 152
[silent-bloc compression: .06]

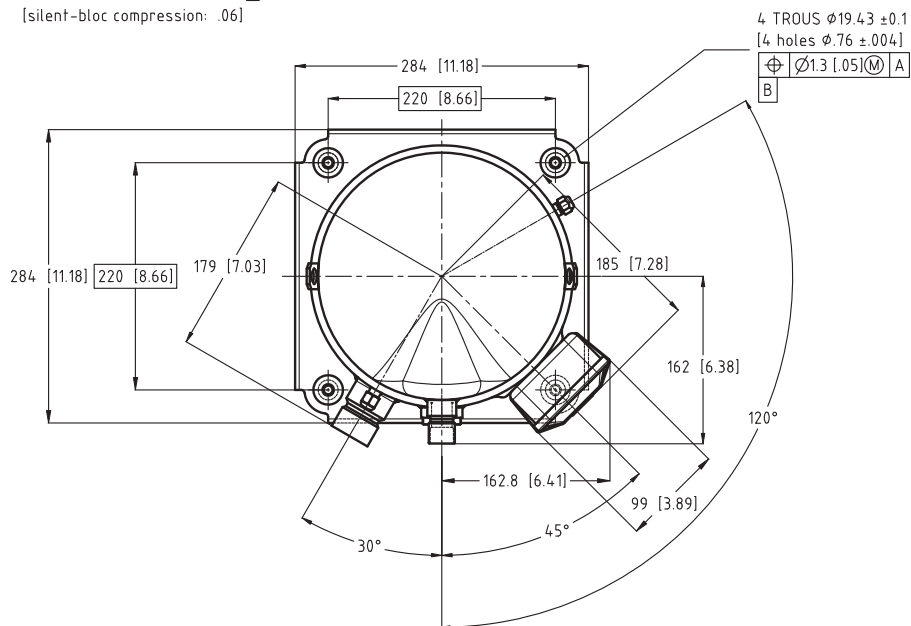

B	PEP	13/06/00	MAP	DM 980927	
A	PEP	22/09/99	SOP	CREATION DM 990234	
IND	RT	PAR	DATE	APPROBATIONS	OBSERVATIONS
MATERIE:					
Ech:	1/4	Tol.gén.:	± 0.8 [± .03] ± 2°		
ENCOMBEMENT S110/120 - V					
S110/120 - V OUTLINE					
Ce plan est la propriété de Maneurop SA Toute copie ou communication à des tiers est interdite sans autorisation					
				Danfoss Maneurop S.A. Z.I. de REYRIEUX - B.P. 331F 01603 TREVOUX - FRANCE	
				85 52 037	