

Di=134.8 (0 133)

Di=105.5 (4-1/8")

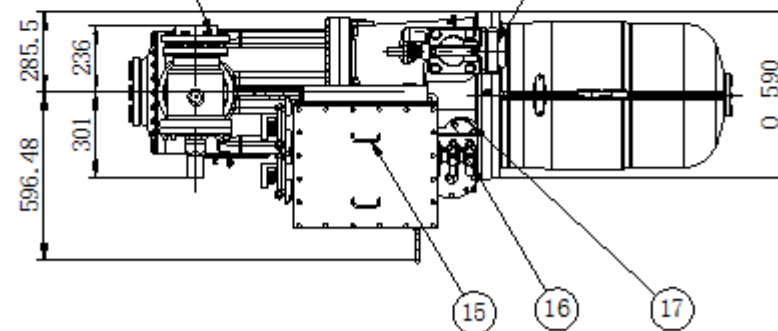

Key:

- | | |
|--|---|
| 1-Anti-vibration damper | 11-Oil filter |
| 2-Oil drain port on low pressure side 1/4"-18NPT | 12-Discharge shut-off valve |
| 3-High pressure connection 1/4"SAE-FLARE | 13-Suction shut-off valve |
| 4-Oil switch (option) | 14-Check valve |
| 5-Low pressure connection 1/4"SAE-FLARE | 15-Anti-explosion terminal box |
| 6-Anti-explosion VI capacity control (option) | 16-Anti-explosion cooling capacity control |
| 7-Oil sight glass | 17-Liquid injection connection \varnothing 10/Economizer connection \varnothing 42 (option) |
| 8-PTC110°C | 18-Oil pressure connection 1/4"SAE-FLARE |
| 9-Oil charge/drain valve 3/8"SAE-FLARE | |
| 10-Anti-explosion oil heater | |

Screw compressor SRC-S-885

RefComp