



ADVANCED HEAT EXCHANGERS

BRAZED PLATE

ADVANCED HEAT EXCHANGERS

ONDA is a leading company in Heat Exchange, partner of all main Chiller manufacturers. ONDA produces a complete range of Shell & Tube and Braze Plate Heat Exchangers dedicated to Refrigeration and Air Conditioning. Our evaporators and condensers are available with different raw materials and well adapted to different refrigerants (R22, R134a, R410A...) from 3 to 850 Tons. All our products are manufactured under ISO 9001 with all the main worldwide certifications: ASME, GOST, GL, PED, RINA, UL.

TECHNICAL INFORMATION

The main applications of our braze plate heat exchangers are the evaporation and the condensation of the refrigerant gas in the air conditioning and refrigeration plants, the hot water production in heat pumps, the heat recovery.

Suitable refrigerants are all HCFCs, HFCs and others, unless they are compatible with the manufacturing materials.

The dimensional data contained in this catalogue are to be intended indicative taking into account the manufacturing tolerances. We reserve the right to apply changes to this catalogue without prior notice.

MATERIALS

The top quality materials used to manufacture the ONDA braze plate heat exchangers satisfy the requirements of the 97/23/EC Directive (Pressure Equipment Directive).

The type construction of the braze plate heat exchangers consists of:

Plate heat exchangers Stainless steel thickness 0,30MM 0,012" (316L type).
 Connections Stainless steel (304L type).
 Brazing material Copper

ACCESSORIES

Following optionals are available on request:

- Loose or welded mounting supports
- Insulation.

ONDA Braze plate heat exchangers carry the UL Mark for US and Canada (ref. no.SA32759)



Configuration - connections SINGLE CIRCUIT								
FOUR connections								Code
F1	F2	W1	W2					AA
F1	F2			BW1	BW2			AB
F1	F2	W1			BW2			AC
F1	F2		W2	BW1				AD
	F2	W1		BW1			BF2	AE
	F2	W1			BW2	BF1		AF
F1			W2		BW2	BF1		AG
F1			W2	BW1		BF2		AH
FIVE connections								
F1	F2	W1	W2	BW1				BA
F1	F2	W1	W2			BW2		BB
F1	F2	W1		BW1	BW2			BC
F1	F2		W2	BW1	BW2			BD
SIX connections								
F1	F2	W1	W2	BW1	BW2			CA
F1	F2	W1	W2			BF1	BF2	CB
F1	F2	W1	W2	BW1			BF2	CC
F1	F2	W1	W2		BW2	BF1		CD
EIGHT connections								
F1	F2	W1	W2	BW1	BW2	BF1	BF2	DA
Configuration - connections DUAL CIRCUIT								
SIX connections								
F1	F2	G1	G2			BW1	BW2	MA
F1	F2	G1	G2	W1	W2			MB
SEVEN connections								
F1	F2	G1	G2	W1		BW1	BW2	NA
F1	F2	G1	G2		W2	BW1	BW2	NB
F1	F2	G1	G2	W1	W2	BW1		NC
F1	F2	G1	G2	W1	W2		BW2	ND
EIGHT connections								
F1	F2	G1	G2	W1	W2	BW1	BW2	PA

Progressive number to identify size & type connections

Operating conditions **D** = evaporator with distributor **H** = High Pressure
HD = High Pressure with distributor

Model 09, 12, 22, 82, 182, 202, 222, 404, 424, 606

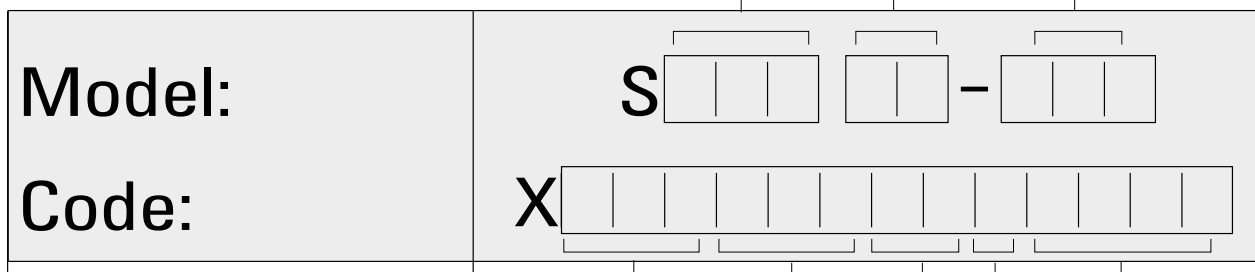

Model 09, 12, 22, 82, 182, 202, 222, 404, 424, 606

Numbers of plates

Configuration connections

Operating **Single circuit** **0** = evaporator condenser **1** = evaporator with distributor
2 = High Pressure **3** = High Pressure with distributor

Dual Circuit: **4** = Cross circuit refrigerant **5** = Cross circuit refrigerant with distributor
6 = High Pressure refrigerant **7** = High Pressure refrigerant plus distributor

Progressive number to identify size & type connections

PLEASE READ OPERATING AND INSTRUCTIONS MANUAL BEFORE USE

S06 SINGLE CIRCUIT

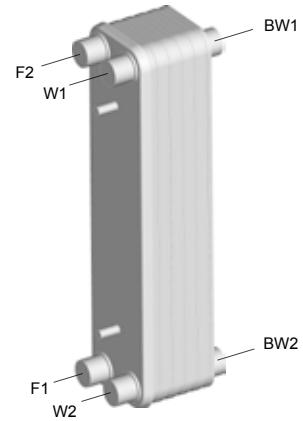
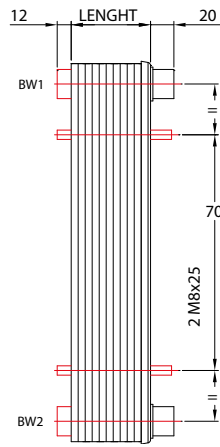
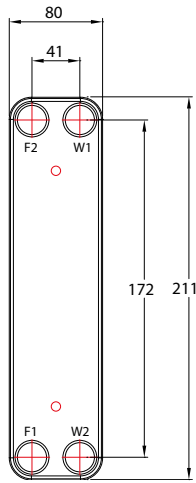

F1 INLET Refrigerant W1-BW1 INLET Secondary Fluid
 F2 OUTLET Refrigerant W2-BW2 OUTLET Secondary Fluid

SPECIFICATIONS	S06	S06H	CONNECTIONS TYPE			
PRESSURE RANGE (bar)	Vacuum to 30	Vacuum to 45	Soldering	Threaded M	Threaded F	Rotalock
TEMPERATURE RANGE (°C)	-100°C to +120°C	-100°C to +120°C	S6	C22	F22	R19
MAXIMUM CONNECTIONS AVAILABLE (mm)	18	18	S8	C27	IF22	R25
MAXIMUM FLOW RATE (m3/h)	5,22	5,22	S12	G22	IF6	
VOLUME / CHANNEL (liters)	0,0346	0,0346	S14	G27	IF8	
DIMENSIONS (mm)	80 x 211	80 x 211	S16	IC22		
LENGHT CALCULATION (mm)	$N \times 2,35 + 4$	$N \times 2,35 + 4$	S18	IC27		
WEIGHT CALCULATION (kg)	$N \times 0,05 + 0,7$	$N \times 0,05 + 0,7$	S19			
	SAME "H" DESIGN		S20			
			Standard connections: F1 S18 F2 S20 W1-W2 C22			
			FOR SPECIAL CONNECTIONS SEE PAGE 19 AND 20			

N Number of plates

LETTER TO IDENTIFY CONNECTIONS TYPE

- S** Soldering Connections
- C** Conical Male Gas Threaded Connections
- G** Cylindric Male Gas Threaded Connections
- F** Female Gas Threaded Connections
- R** Rotalock Connections Male

PLATE HEAT EXCHANGER MATERIAL Stainless Steel 316L Thickness 0,30 mm

BRAZING MATERIAL Copper (Cu)

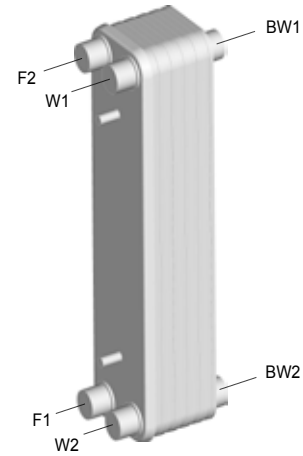
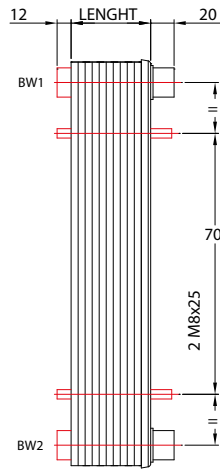
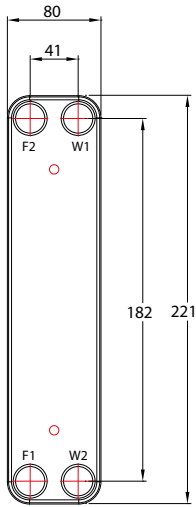

F1 INLET Refrigerant W1-BW1 INLET Secondary Fluid
 F2 OUTLET Refrigerant W2-BW2 OUTLET Secondary Fluid

SPECIFICATIONS	S07	S07H	CONNECTIONS TYPE			
PRESSURE RANGE (bar)	Vacuum to 30	Vacuum to 45	Soldering	Threaded M	Threaded F	Rotalock
TEMPERATURE RANGE (°C)	-100°C to +120°C	-100°C to +120°C	S6	C22	F22	R19
MAXIMUM CONNECTIONS AVAILABLE (mm)	18	18	S8	C27	IF22	R25
MAXIMUM FLOW RATE (m³/h)	5,2	5,2	S12	G22	IF6	
VOLUME / CHANNEL (liters)	0,036	0,036	S14	G27	IF8	
DIMENSIONS (mm)	80 x 221	80 x 221	S16	IC22		
LENGHT CALCULATION (mm)	$N \times 2,35 + 4$	$N \times 2,35 + 4$	S18	IC27		
WEIGHT CALCULATION (kg)	$N \times 0,06 + 0,7$	$N \times 0,06 + 0,7$	S19			
	SAME "H" DESIGN		S20			
			Standard connections: F1 S18 F2 S20 W1-W2 C22			
			FOR SPECIAL CONNECTIONS SEE PAGE 19 AND 20			

N Number of plates

LETTER TO IDENTIFY CONNECTIONS TYPE

- S** Soldering Connections
- C** Conical Male Gas Threaded Connections
- G** Cylindric Male Gas Threaded Connections
- F** Female Gas Threaded Connections
- R** Rotalock Connections Male

PLATE HEAT EXCHANGER MATERIAL Stainless Steel 316L Thickness 0,30 mm

BRAZING MATERIAL Copper (Cu)

S09 SINGLE CIRCUIT

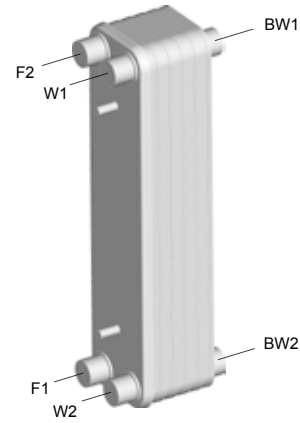
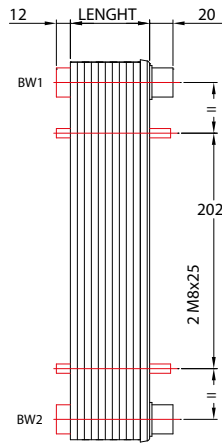
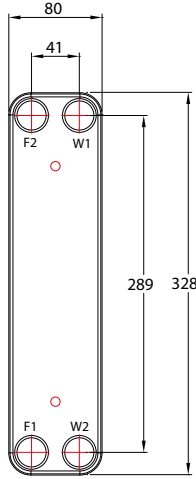

F1 INLET Refrigerant W1-BW1 INLET Secondary Fluid
 F2 OUTLET Refrigerant W2-BW2 OUTLET Secondary Fluid

SPECIFICATIONS	S09	S09H	CONNECTIONS TYPE			
PRESSURE RANGE (bar)	Vacuum to 30	Vacuum to 45	Soldering	Threaded M	Threaded F	Rotalock
TEMPERATURE RANGE (°C)	-100°C to +120°C	-100°C to +120°C	S6	C22	F22	R19
MAXIMUM CONNECTIONS AVAILABLE (mm)	18	18	S8	C27	IF22	R25
MAXIMUM FLOW RATE (m3/h)	5,22	5,22	S12	G22	IF6	
VOLUME / CHANNEL (liters)	0,047	0,047	S14	G27	IF8	
DIMENSIONS (mm)	80 x 328	80 x 328	S16	IC22		
LENGHT CALCULATION (mm)	$N \times 2,35 + 10$	$N \times 2,35 + 10$	S18	IC27		
WEIGHT CALCULATION (kg)	$N \times 0,08 + 1$	$N \times 0,08 + 1$	S19			
	SAME "H" DESIGN		S20			
			Standard connections: F1 S18 F2 S20 W1-W2 C22			
			FOR SPECIAL CONNECTIONS SEE PAGE 19 AND 20			

N Number of plates

LETTER TO IDENTIFY CONNECTIONS TYPE

- S** Soldering Connections
- C** Conical Male Gas Threaded Connections
- G** Cylindric Male Gas Threaded Connections
- F** Female Gas Threaded Connections
- R** Rotalock Connections Male

PLATE HEAT EXCHANGER MATERIAL Stainless Steel 316L Thickness 0,30 mm

BRAZING MATERIAL Copper (Cu)

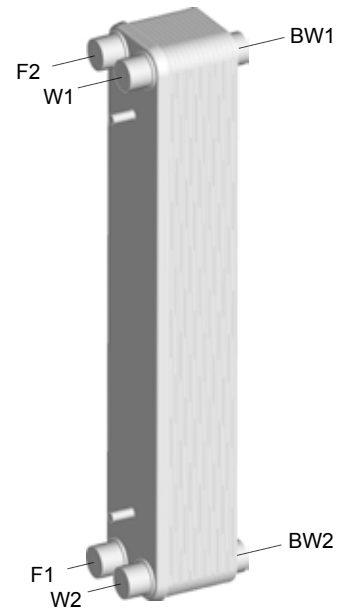
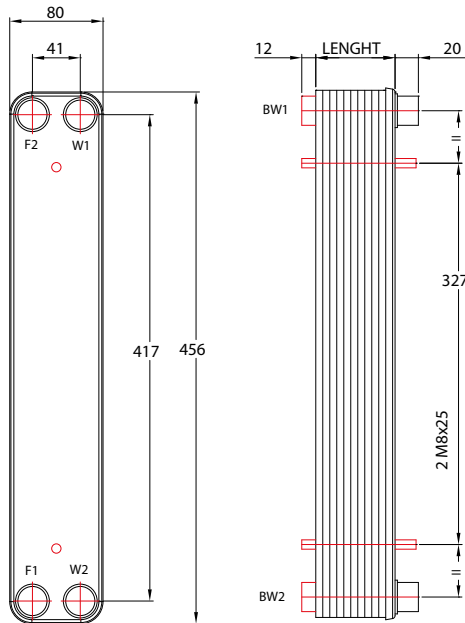

F1 INLET Refrigerant W1-BW1 INLET Secondary Fluid
 F2 OUTLET Refrigerant W2-BW2 OUTLET Secondary Fluid

SPECIFICATIONS	S22	S22H
PRESSURE RANGE (bar)	Vacuum to 30	Vacuum to 45
TEMPERATURE RANGE (°C)	-100°C to +120°C	-100°C to +120°C
MAXIMUM CONNECTIONS AVAILABLE (mm)	18	18
MAXIMUM FLOW RATE (m3/h)	5,22	5,22
VOLUME / CHANNEL (liters)	0,064	0,064
DIMENSIONS (mm)	80 x 456	80 x 456
LENGHT CALCULATION (mm)	$N \times 2,35 + 10$	$N \times 2,35 + 12$
WEIGHT CALCULATION (kg)	$N \times 0,1 + 1,5$	$N \times 0,1 + 3,5$

CONNECTIONS TYPE			
Soldering	Threaded M	Threaded F	Rotalock
S6	C22	F22	R19
S8	C27	IF22	R25
S12	G22	IF6	
S14	G27	IF8	
S16	IC22		
S18	IC27		
S19			
S20			
Standard connections: F1 S18 F2 S20 W1-W2 C22 FOR SPECIAL CONNECTIONS SEE PAGE 19 AND 20			

N Number of plates

LETTER TO IDENTIFY CONNECTIONS TYPE

- S** Soldering Connections
- C** Conical Male Gas Threaded Connections
- G** Cylindric Male Gas Threaded Connections
- F** Female Gas Threaded Connections
- R** Rotalock Connections Male

PLATE HEAT EXCHANGER MATERIAL Stainless Steel 316L Thickness 0,30 mm

BRAZING MATERIAL Copper (Cu)

S12 SINGLE CIRCUIT

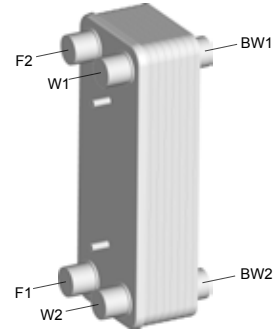
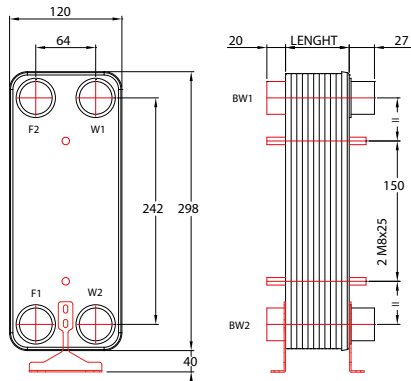

F1 INLET Refrigerant W1-BW1 INLET Secondary Fluid
 F2 OUTLET Refrigerant W2-BW2 OUTLET Secondary Fluid

SPECIFICATIONS	S12	S12H
PRESSURE RANGE (bar)	Vacuum to 30	Vacuum to 45
TEMPERATURE RANGE (°C)	-100°C to +120°C	-100°C to +80°C
MAXIMUM CONNECTIONS AVAILABLE (mm)	30,1	30,1
MAXIMUM FLOW RATE (m3/h)	14,07	14,07
VOLUME / CHANNEL (liters)	0,072	0,072
DIMENSIONS (mm)	120 x 298	120 x 298
LENGHT CALCULATION (mm)	$N \times 2,35 + 10$	$N \times 2,35 + 12$
WEIGHT CALCULATION (kg)	$N \times 0,112 + 1,7$	$N \times 0,112 + 4$

CONNECTIONS TYPE				
Soldering	Threaded M	Threaded F	Grooved	Rotalock
S6	C22	F22	V32	R19
S8	IC22	F27	BV32	R25
S12	C27	F32	V40	R32
S14	IC27	F42	BV40	R44
S16	C32	IF22		
S18	IC32	IF27		
S19	C42	IF32		
S22	IC42	IF42		
S28	G22			
S30	G27			
	G32			
	G42			
Standard Connections: F1 S22 F2 S28 W1-W2 C32				
FOR SPECIAL CONNECTIONS SEE PAGE 19 AND 20				

N Number of plates

LETTER TO IDENTIFY CONNECTIONS TYPE

- S** Soldering Connections
- C** Conical Male Gas Threaded Connections
- G** Cylindric Male Gas Threaded Connections
- F** Female Gas Threaded Connections
- V-BV** Grooved System for Standard Flexible Coupling
- R** Rotalock Connections Male

PLATE HEAT EXCHANGER MATERIAL Stainless Steel 316L Thickness 0,30 mm
 BRAZING MATERIAL Copper (Cu)

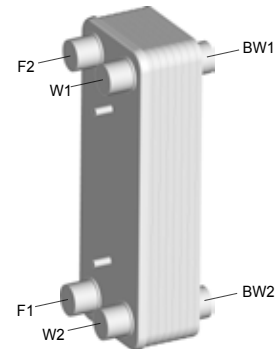
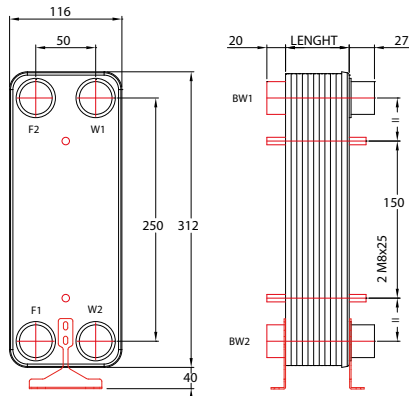

F1 INLET Refrigerant W1-BW1 INLET Secondary Fluid
 F2 OUTLET Refrigerant W2-BW2 OUTLET Secondary Fluid

SPECIFICATIONS	S16	S16H
PRESSURE RANGE (bar)	Vacuum to 30	Vacuum to 45
TEMPERATURE RANGE (°C)	-100°C to +120°C	-100°C to +80°C
MAXIMUM CONNECTIONS AVAILABLE (mm)	34	34
MAXIMUM FLOW RATE (m3/h)	14,07	14,07
VOLUME / CHANNEL (liters)	0,07	0,07
DIMENSIONS (mm)	312 X 116	312 X 116
LENGHT CALCULATION (mm)	$N \times 2,35 + 10$	$N \times 2,35 + 12$
WEIGHT CALCULATION (kg)	$N \times 0,11 + 2$	$N \times 0,11 + 4,5$

CONNECTIONS TYPE				
Soldering	Threaded M	Threaded F	Grooved	Rotalock
S6	C22	F22	V32	R19
S8	IC22	F27	BV32	R25
S12	C27	F32	V40	R32
S14	IC27	IF22	BV40	
S16	C32	IF27		
S18	IC32	IF32		
S19	G22			
S22	G27			
S28	G32			
S30				
Standard Connections: F1 S22 F2 S28 W1-W2 C32				
FOR SPECIAL CONNECTIONS SEE PAGE 19 AND 20				

N Number of plates

LETTER TO IDENTIFY CONNECTIONS TYPE

- S** Soldering Connections
- C** Conical Male Gas Threaded Connections
- G** Cylindric Male Gas Threaded Connections
- F** Female Gas Threaded Connections
- V-BV** Grooved System for Standard Flexible Coupling
- R** Rotalock Connections Male

PLATE HEAT EXCHANGER MATERIAL Stainless Steel 316L Thickness 0,30 mm
 BRAZING MATERIAL Copper (Cu)

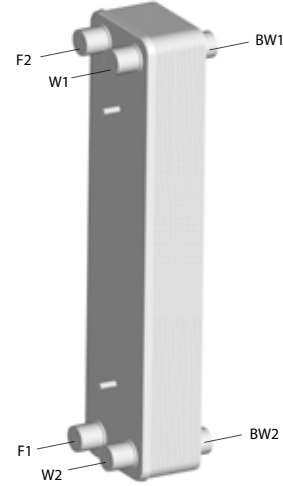
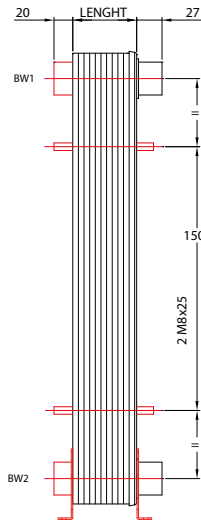
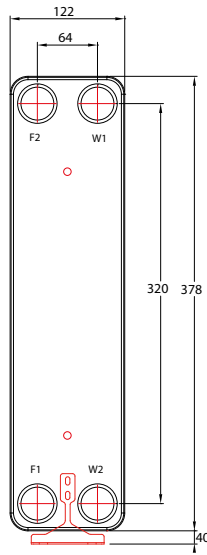

F1 INLET Refrigerant W1-BW1 INLET Secondary Fluid
 F2 OUTLET Refrigerant W2-BW2 OUTLET Secondary Fluid

SPECIFICATIONS	S62	S62H
PRESSURE RANGE (bar)	Vacuum to 30	Vacuum to 45
TEMPERATURE RANGE (°C)	-100°C to +120°C	-100°C to +120°C
MAXIMUM CONNECTIONS AVAILABLE (mm)	38,9	38,9
MAXIMUM FLOW RATE (m3/h)	23,6	23,6
VOLUME / CHANNEL (liters)	0,08	0,08
DIMENSIONS (mm)	122 x 378	122 x 378
LENGHT CALCULATION (mm)	$N \times 2,15 + 10$	$N \times 2,15 + 12$
WEIGHT CALCULATION (kg)	$N \times 0,13 + 2$	$N \times 0,13 + 5$

CONNECTIONS TYPE				
Soldering	Threaded M	Threaded F	Grooved	Rotalock
S6	C22	F22	V32	R19
S8	IC22	F27	BV32	R25
S12	C27	F32	V40	R32
S14	IC27	F42	BV40	R44
S16	C32	IF22		
S18	IC32	IF27		
S19	C42	IF32		
S22	IC42	IF42		
S28	G22			
S30	G27			
	G32			
	G42			
Standard Connections: F1 S22 F2 S30 W1-W2 C42				
FOR SPECIAL CONNECTIONS SEE PAGE 19 AND 20				

N Number of plates

LETTER TO IDENTIFY CONNECTIONS TYPE

- S** Soldering Connections
- C** Conical Male Gas Threaded Connections
- G** Cylindric Male Gas Threaded Connections
- F** Female Gas Threaded Connections
- V-BV** Grooved System for Standard Flexible Coupling
- R** Rotalock Connections Male

PLATE HEAT EXCHANGER MATERIAL Stainless Steel 316L Thickness 0,30 mm
 BRAZING MATERIAL Copper (Cu)

S82-S82M



SINGLE CIRCUIT

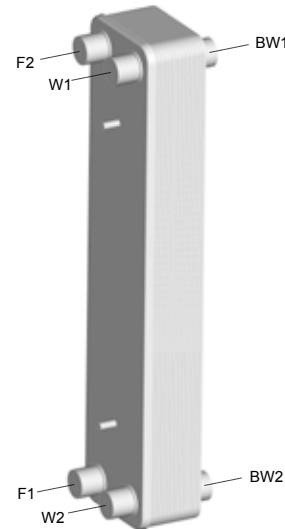
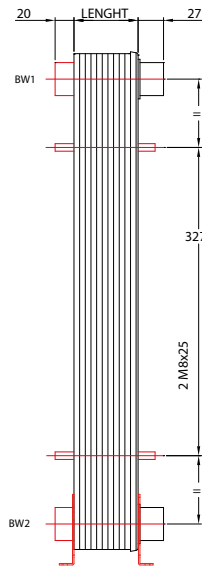
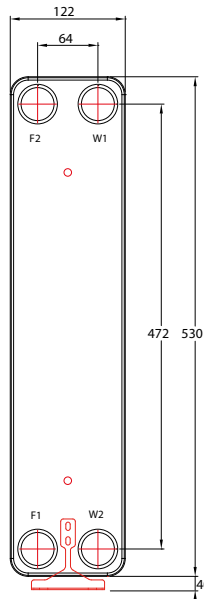

F1 INLET Refrigerant W1-BW1 INLET Secondary Fluid
 F2 OUTLET Refrigerant W2-BW2 OUTLET Secondary Fluid

SPECIFICATIONS	S82	S82H
PRESSURE RANGE (bar)	Vacuum to 30	Vacuum to 45
TEMPERATURE RANGE (°C)	-100°C to +120°C	-100°C to +120°C
MAXIMUM CONNECTIONS AVAILABLE (mm)	38,9	38,9
MAXIMUM FLOW RATE (m3/h)	23,6	23,6
VOLUME / CHANNEL (liters)	0,113	0,113
DIMENSIONS (mm)	122 x 530	122 x 530
LENGHT CALCULATION (mm)	$N \times 2,15 + 10$	$N \times 2,15 + 12$
WEIGHT CALCULATION (kg)	$N \times 0,18 + 3$	$N \times 0,18 + 7$

CONNECTIONS TYPE				
Soldering	Threaded M	Threaded F	Grooved	Rotalock
S6	C22	F22	V32	R19
S8	IC22	F27	BV32	R25
S12	C27	F32	V40	R32
S14	IC27	F42	BV40	R44
S16	C32	IF22		
S18	IC32	IF27		
S19	C42	IF32		
S22	IC42	IF42		
S28	G22			
S30	G27			
	G32			
	G42			
Standard Connections: F1 S22 F2 S30 W1-W2 C42				
FOR SPECIAL CONNECTIONS SEE PAGE 19 AND 20				

N Number of plates

LETTER TO IDENTIFY CONNECTIONS TYPE

- S** Soldering Connections
- C** Conical Male Gas Threaded Connections
- G** Cylindric Male Gas Threaded Connections
- F** Female Gas Threaded Connections
- V-BV** Grooved System for Standard Flexible Coupling
- R** Rotalock Connections Male

PLATE HEAT EXCHANGER MATERIAL Stainless Steel 316L Thickness 0,30 mm
 BRAZING MATERIAL Copper (Cu)

S101 SINGLE CIRCUIT

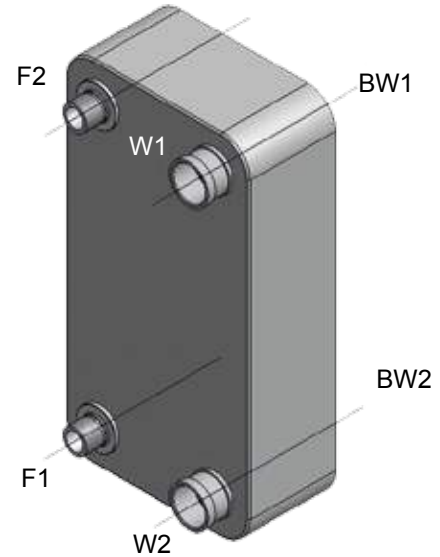
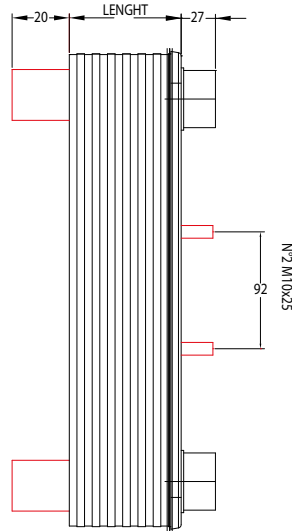
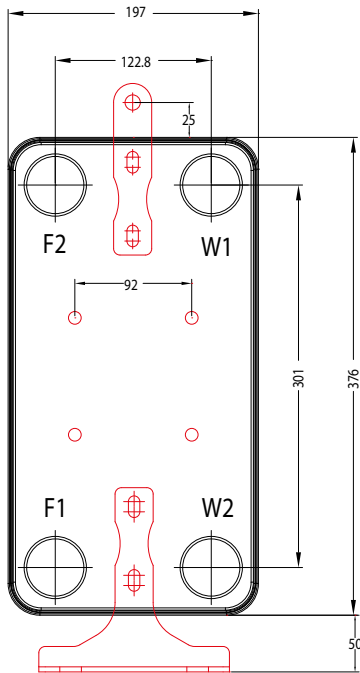

F1 INLET Refrigerant W1-BW1 INLET Secondary Fluid
 F2 OUTLET Refrigerant W2-BW2 OUTLET Secondary Fluid

SPECIFICATIONS	S101	S101H
PRESSURE RANGE (bar)	Vacuum to 30	Vacuum to 45
TEMPERATURE RANGE (°C)	-100°C to +120°C	-100°C to +120°C
MAXIMUM CONNECTIONS AVAILABLE (mm)	42	42
MAXIMUM FLOW RATE (m3/h)	35	35
VOLUME / CHANNEL (liters)	0,145	0,145
DIMENSIONS (mm)	197 x 376	197 x 376
LENGHT CALCULATION (mm)	$N \times 2,15 + 10$	$N \times 2,15 + 10$
WEIGHT CALCULATION (kg)	$N \times 0,22 + 9$	$N \times 0,22 + 9$
SAME "H" DESIGN		

CONNECTIONS TYPE				
Soldering	Threaded M	Threaded F	Grooved	Rotalock
S22	C32	F27	V32	R32
S28	C42	F32	V40	R44
S30	G32	F42		
S42	G42	IF27		
S50	IC32	IF32		
	IC42	IF42		
Standard Connections: F1 S30 F2 S50 W1-W2 C42 FOR SPECIAL CONNECTIONS SEE PAGE 19 AND 20				

N Number of plates

LETTER TO IDENTIFY CONNECTIONS TYPE

- S** Soldering Connections
- C** Conical Male Gas Threaded Connections
- G** Cylindric Male Gas Threaded Connections
- F** Female Gas Threaded Connections
- V-BV** Grooved System for Standard Flexible Coupling
- R** Rotalock Connections Male

PLATE HEAT EXCHANGER MATERIAL Stainless Steel 316L Thickness 0,30 mm
 BRAZING MATERIAL Copper (Cu)

S182-S182M



SINGLE CIRCUIT

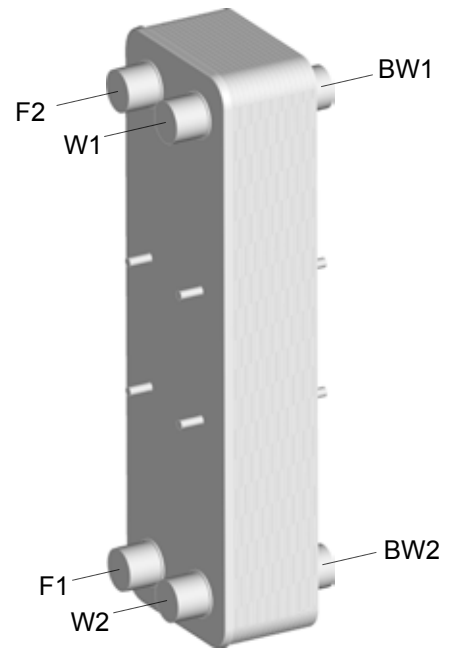
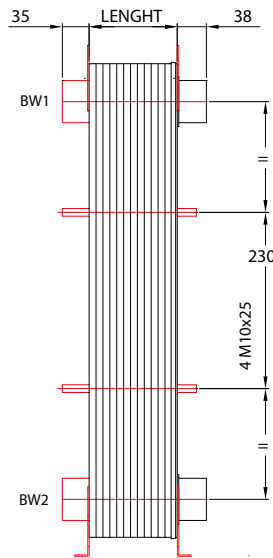
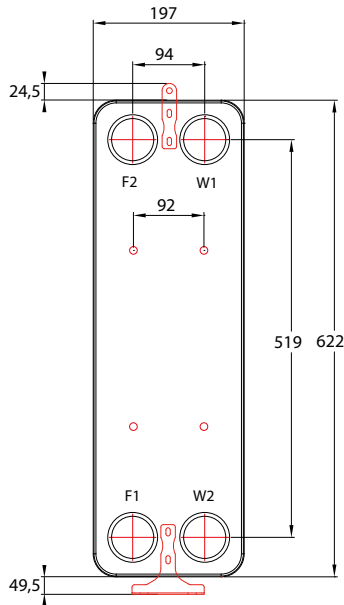

F1 INLET Refrigerant W1-BW1 INLET Secondary Fluid
 F2 OUTLET Refrigerant W2-BW2 OUTLET Secondary Fluid

SPECIFICATIONS	S182	S182H	CONNECTIONS TYPE					
			Soldering	Threaded M	Threaded F	Grooved	Rotalock	Flanges
PRESSURE RANGE (bar)	Vacuum to 30	Vacuum to 45	S22	C48	F48	V50	R32	CF66
TEMPERATURE RANGE (°C)	-100°C to +120°C	-100°C to +120°C	S28	IC48	F60	V65	R44	
MAXIMUM CONNECTIONS AVAILABLE (mm)	57	57	S30	C60	IF48		R58	
MAXIMUM FLOW RATE (m3/h)	50	50	S42	IC60	IF60			
VOLUME / CHANNEL (liters)	0,24	0,24	S54	IC70				
DIMENSIONS (mm)	197 x 622	197 x 622	S60	G48				
LENGHT CALCULATION (mm)	$N \times 2,35 + 10$	$N \times 2,35 + 10$		G60				
WEIGHT CALCULATION (kg)	$N \times 0,36 + 14$	$N \times 0,36 + 14$		G70				
SAME "H" DESIGN			Standard Connections: F1 S30 F2 S54 W1-W2 C60					
			FOR SPECIAL CONNECTIONS SEE PAGE 19 AND 20					

N Number of plates

LETTER TO IDENTIFY CONNECTIONS TYPE

- S** Soldering Connections
- C** Conical Male Gas Threaded Connections
- G** Cylindric Male Gas Threaded Connections
- F** Female Gas Threaded Connections
- V-BV** Grooved System for Standard Flexible Coupling
- R** Rotalock Connections Male

PLATE HEAT EXCHANGER MATERIAL Stainless Steel 316L Thickness 0,30 mm
 BRAZING MATERIAL Copper (Cu)

S202 - S202M

SINGLE CIRCUIT

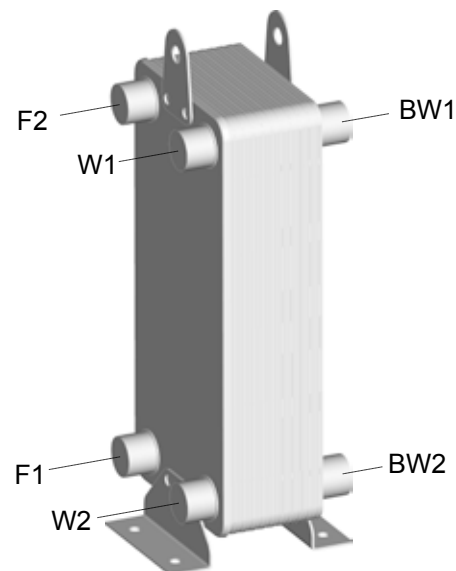
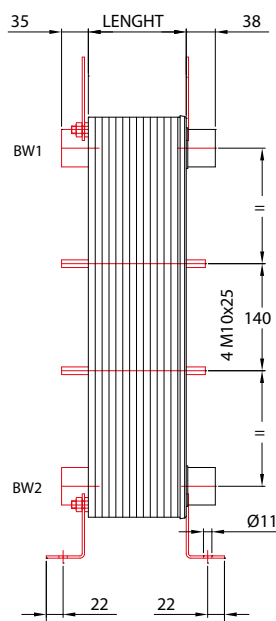
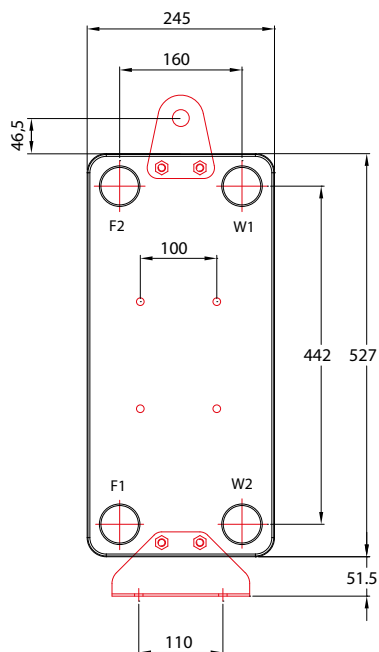

F1 INLET Refrigerant W1-BW1 INLET Secondary Fluid
 F2 OUTLET Refrigerant W2-BW2 OUTLET Secondary Fluid

SPECIFICATIONS	S202	S202H
PRESSURE RANGE (bar)	Vacuum to 30	Vacuum to 45
TEMPERATURE RANGE (°C)	-100°C to +120°C	-100°C to +120°C
MAXIMUM CONNECTIONS AVAILABLE (mm)	57	57
MAXIMUM FLOW RATE (m3/h)	50,62	50,62
VOLUME / CHANNEL (liters)	0,254	0,254
DIMENSIONS (mm)	245 x 527	245 x 527
LENGHT CALCULATION (mm)	$N \times 2,35 + 10$	$N \times 2,35 + 12$
WEIGHT CALCULATION (kg)	$N \times 0,38 + 12$	$N \times 0,38 + 19$

CONNECTIONS TYPE					
Soldering	Threaded M	Threaded F	Grooved	Rotalock	Flanges
S22	C48	F48	V50	R32	CF66
S28	IC48	F60	V65	R44	
S30	C60	IF48		R58	
S42	IC60	IF60			
S54	G48				
S60	G60				
	G70				
Standard Connections: F1 S30 F2 S54 W1-W2 C60					
FOR SPECIAL CONNECTIONS SEE PAGE 19 AND 20					

N Number of plates

LETTER TO IDENTIFY CONNECTIONS TYPE

- S** Soldering Connections
- C** Conical Male Gas Threaded Connections
- G** Cylindric Male Gas Threaded Connections
- F** Female Gas Threaded Connections
- V-BV** Grooved System for Standard Flexible Coupling
- R** Rotalock Connections Male

PLATE HEAT EXCHANGER MATERIAL Stainless Steel 316L Thickness 0,30 mm
 BRAZING MATERIAL Copper (Cu)

SINGLE CIRCUIT

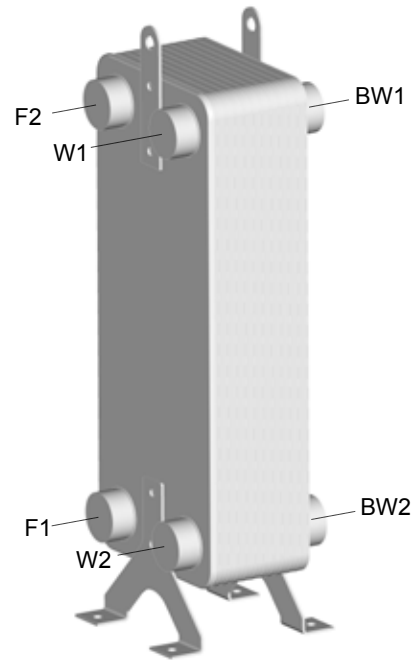
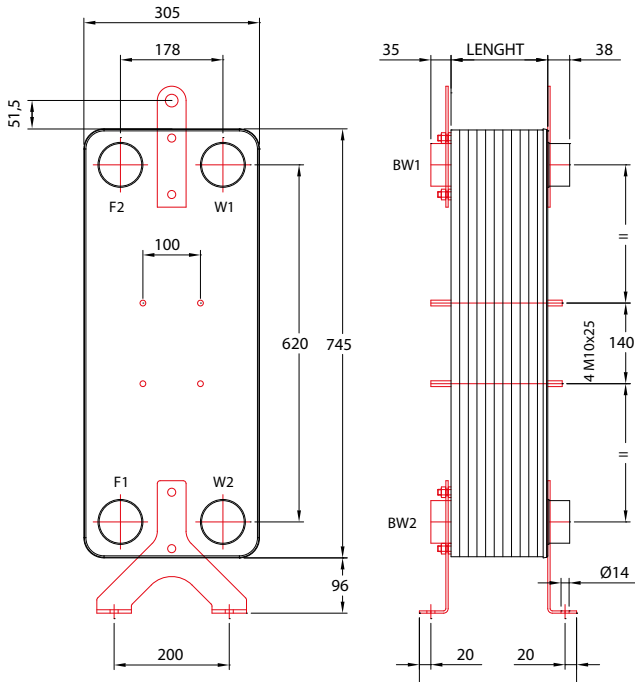

F1 INLET Refrigerant W1-BW1 INLET Secondary Fluid
 F2 OUTLET Refrigerant W2-BW2 OUTLET Secondary Fluid

SPECIFICATIONS	S404
PRESSURE RANGE (bar)	Vacuum to 30
TEMPERATURE RANGE (°C)	-100°C to +120°C
MAXIMUM CONNECTIONS AVAILABLE (mm)	84,7
MAXIMUM FLOW RATE (m3/h)	111,68
VOLUME / CHANNEL (liters)	0,56
DIMENSIONS (mm)	305 x 745
LENGHT CALCULATION (mm)	$N \times 2,85 + 12$
WEIGHT CALCULATION (kg)	$N \times 0,65 + 36$

CONNECTIONS TYPE					
Soldering	Threaded M	Threaded F	Grooved	Rotalock	Flanges
S54	C76	F22	V76	R58	NF80
S64	IC73	F27	V80		CF80
S76	C90	IF22	V90		CF65
S90	IC90	IF27			
	G76	IF32			
	G90				
Standard Connections: F1 S54 F2 S76 W1-W2 G90					
FOR SPECIAL CONNECTIONS SEE PAGE 19 AND 20					

N Number of plates

LETTER TO IDENTIFY CONNECTIONS TYPE

- S** Soldering Connections
- C** Conical Male Gas Threaded Connections
- G** Cylindric Male Gas Threaded Connections
- F** Female Gas Threaded Connections
- V-BV** Grooved System for Standard Flexible Coupling
- R** Rotalock Connections Male

PLATE HEAT EXCHANGER MATERIAL Stainless Steel 316L Thickness 0,30 mm
 BRAZING MATERIAL Copper (Cu)

S606 - S606M

SINGLE CIRCUIT

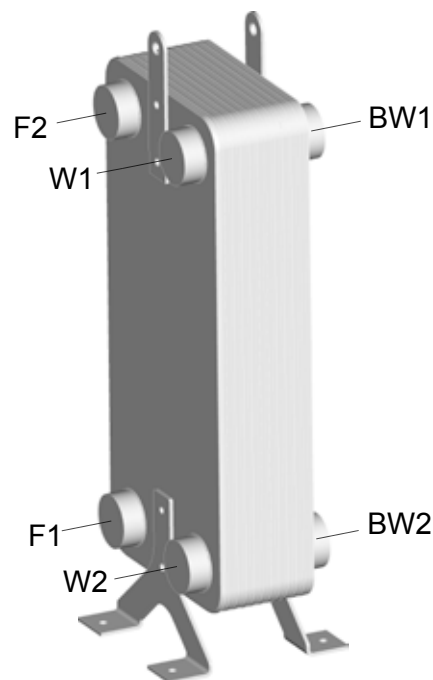
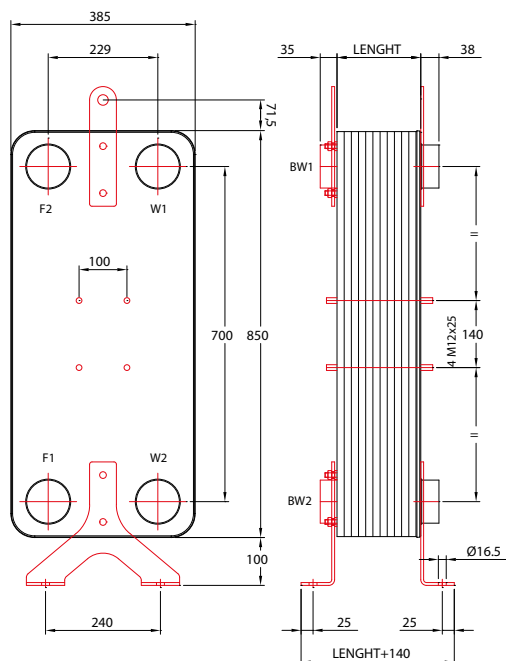

F1 INLET Refrigerant W1-BW1 INLET Secondary Fluid
 F2 OUTLET Refrigerant W2-BW2 OUTLET Secondary Fluid

SPECIFICATIONS	S606
PRESSURE RANGE (bar)	Vacuum to 20
TEMPERATURE RANGE (°C)	-100°C to +120°C
MAXIMUM CONNECTIONS AVAILABLE (mm)	110,1
MAXIMUM FLOW RATE (m3/h)	188,41
VOLUME / CHANNEL (liters)	0,79
DIMENSIONS (mm)	385 x 850
LENGHT CALCULATION (mm)	$N \times 2,85 + 10$
WEIGHT CALCULATION (kg)	$N \times 0,95 + 52$

CONNECTIONS TYPE				
Soldering	Threaded M	Threaded F	Grooved	Flanges
S54	C76	F22	V73	NF100
S64	IC73	F27	V80	NF80
IS65	C90	IF22	V90	CF80
S76	IC90	IF27	V100	CF100
IS80	C100	IF32		
S90	IC100			
IS92	G76			
S100	G90			
	G100			
Standard Connections: F1 S76 F2 S100 W1-W2 V100				
FOR SPECIAL CONNECTIONS SEE PAGE 19 AND 20				

N Number of plates

LETTER TO IDENTIFY CONNECTIONS TYPE

- S** Soldering Connections
- C** Conical Male Gas Threaded Connections
- G** Cylindric Male Gas Threaded Connections
- F** Female Gas Threaded Connections
- V-BV** Grooved System for Standard Flexible Coupling
- R** Rotolock Connections Male

PLATE HEAT EXCHANGER MATERIAL Stainless Steel 316L Thickness 0,30 mm
 BRAZING MATERIAL Copper (Cu)

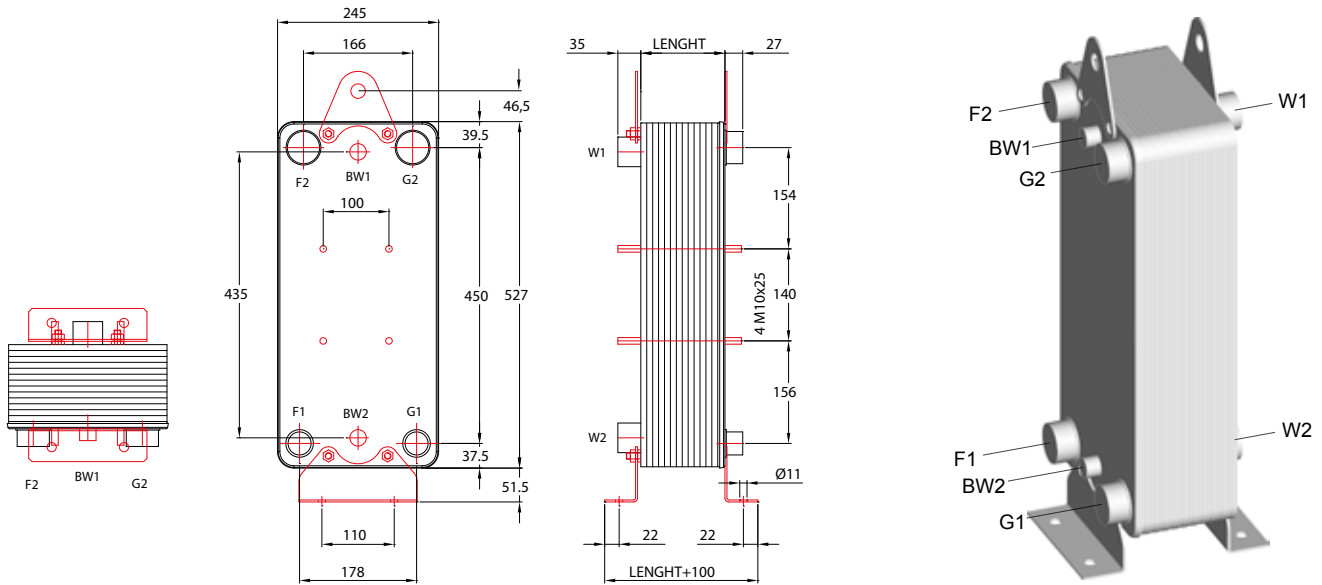

- F1 INLET Refrigerant Circuit 1
- G1 INLET Refrigerant Circuit 2
- W1 INLET Secondary Fluid
- BW1 - BW2 Connections for Sensor
- F2 OUTLET Refrigerant Circuit 1
- G2 OUTLET Refrigerant Circuit 2
- W2 OUTLET Secondary Fluid

SPECIFICATIONS	S222	S222H
PRESSURE RANGE (bar)	Vacuum to 30	Vacuum to 45
TEMPERATURE RANGE (°C)	-100°C to +120°C	-100°C to +120°C
MAXIMUM CONNECTIONS AVAILABLE (mm)	57	57
MAXIMUM FLOW RATE (m3/h)	50,62	50,62
VOLUME / CHANNEL (liters)	0,223	0,223
DIMENSIONS (mm)	245 x 527	245 x 527
LENGHT CALCULATION (mm)	$N \times 2,35 + 10$	$N \times 2,35 + 12$
WEIGHT CALCULATION (kg)	$N \times 0,38 + 12$	$N \times 0,38 + 20$

CONNECTIONS TYPE					
Soldering	Threaded M	Threaded F	Grooved	Rotalock	Flanges
S22	C48	F22	V50	R32	
S28	IC48	F27	V65	R44	CF66
IS29	C60	IF22		R58	
S30	IC60	IF27			
S42	G48				
IS41	G60				
S50					
Standard Connections F1-G1 S28 F2-G2 S42 W1-W2 G60 BW1-BW2 F22					
FOR SPECIAL CONNECTIONS SEE PAGE 19 AND 20					

N Number of plates

LETTER TO IDENTIFY CONNECTIONS TYPE

- S** Soldering Connections
- C** Conical Male Gas Threaded Connections
- G** Cylindric Male Gas Threaded Connections
- F** Female Gas Threaded Connections
- V - BV** Grooved System for Standard Flexible Coupling
- R** Rotalock Connections Male

PLATE HEAT EXCHANGER MATERIAL Stainless Steel 316L Thickness 0,30 mm

BRAZING MATERIAL Copper (Cu)

Criss-Cross Flow Pattern Available on Request

S424 DUAL CIRCUIT

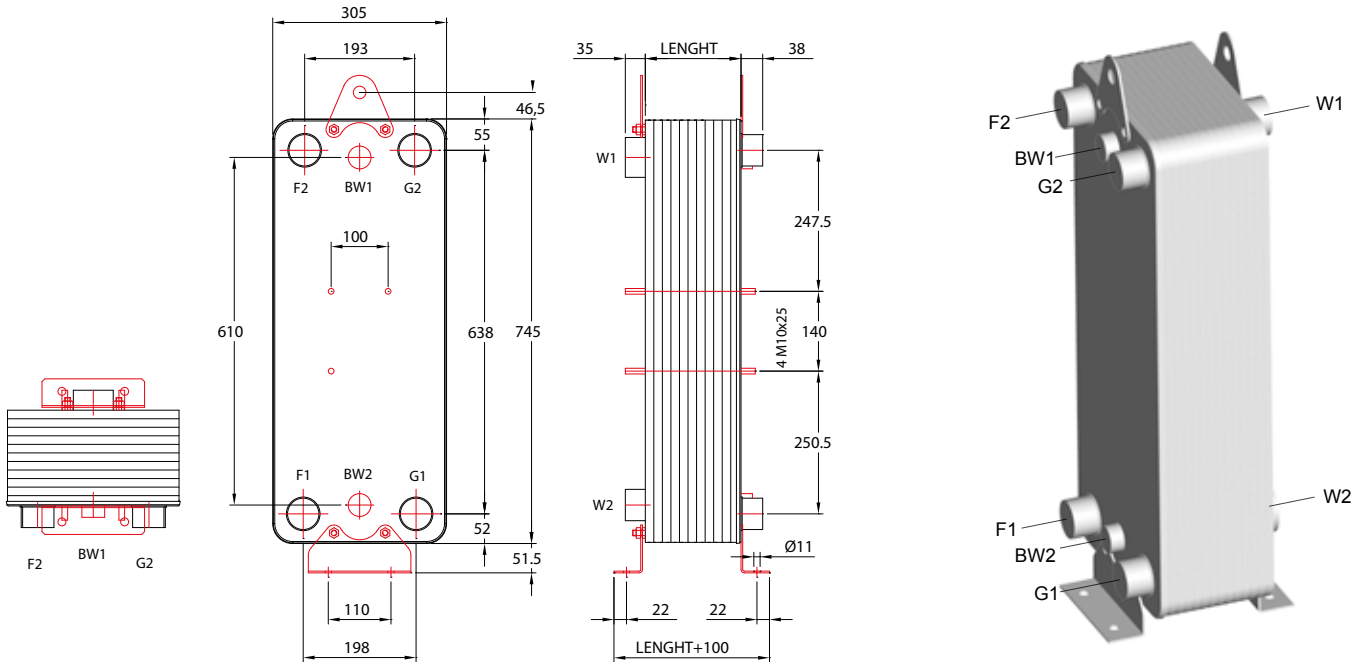

F1 INLET Refrigerant Circuit 1 **F2 OUTLET** Refrigerant Circuit 1
G1 INLET Refrigerant Circuit 2 **G2 OUTLET** Refrigerant Circuit 2
W1 INLET Secondary Fluid **W2 OUTLET** Secondary Fluid
BW1 - BW2 Connections for Sensor

SPECIFICATIONS	S424	S424H	CONNECTIONS TYPE					
			Soldering	Threaded M	Threaded F	Grooved	Rotalock	Flanges
PRESSURE RANGE (bar)	Vacuum to 30	Vacuum to 45	S30	C76	F22	V73	R44	NF80
TEMPERATURE RANGE (°C)	-100°C to +120°C	-100°C to +120°C	S42	IC73	F27	V80	R58	NF65
MAXIMUM CONNECTIONS AVAILABLE (mm)	84,7	84,7	S54	C90	IF22	V90		CF65
MAXIMUM FLOW RATE (m3/h)	111,68	111,68	S64	IC90	IF27			CF80
VOLUME / CHANNEL (liters)	0,484	0,484	IS65	G76				
DIMENSIONS (mm)	305 x 745	305 x 745	S76	G90				
LENGHT CALCULATION (mm)	$N \times 2,85 + 10$	$N \times 2,85 + 12$	IS80					
WEIGHT CALCULATION (kg)	$N \times 0,65 + 36$	$N \times 0,65 + 50$	S90					
			Standard Connections: F1-G1 S54 F2-G2 S76 W1-W2 C90 BW1-BW2 F22					

N Number of plates

LETTER TO IDENTIFY CONNECTIONS TYPE

- S** Soldering Connections
- C** Conical Male Gas Threaded Connections
- G** Cylindric Male Gas Threaded Connections
- F** Female Gas Threaded Connections
- V - BV** Grooved System for Standard Flexible Coupling
- R** Rotalock Connections Male

PLATE HEAT EXCHANGER MATERIAL Stainless Steel 316L Thickness 0,30 mm

BRAZING MATERIAL Copper (Cu)

Criss-Cross Flow Pattern Available on Request

ALL POSSIBLE CONNECTIONS FOR THESE CONNECTIONS CONTACT TECHNICAL DEPT

S06 / S07 / S09 / S22

Soldering	Threated M	Threated F	Rotalock R
S6/20	C22/20	F22/20	R19/20
S8/20	C27/20	IF6/20	R25/20
S12/20	IC22/20	IF8/20	
S14/20	IC27/20	IF22/20	
S16/20	G22/20		
S18/20	G27/20		
S19/20			
S20/20			

S16

Soldering	Threated M	Threated F	Rotalock R	Grooved V
S6/27	C22/27	F22/27	R19/27	V32/27
S8/27	C27/27	F27/27	R25/27	V40/27
S12/27	C32/27	F32/27	R32/27	BV32
S14/27	IC22/27	IF6/27		BV40
S16/27	IC27/27	IF8/27		
S18/27	IC32/27	IF22/27		
S19/27	G22/27	IF27/27		
S22/27	G27/27	IF32/27		
S28/27	G32/27			
S30/27				

S12 / S62 / S82 / S82M

Soldering	Threated M	Threated F	Rotalock R	Grooved V
S6/27	C22/27	F22/27	R19/27	V32/27
S8/27	C27/27	F27/27	R25/27	V40/27
S12/27	C32/27	F32/27	R32/27	BV32
S14/27	C42/27	F42/27	R44/27	BV40
S16/27	IC22/27	IF6/27		
S18/27	IC27/27	IF8/27		
S19/27	IC32/27	IF22/27		
S22/27	IC42/27	IF27/27		
S28/27	G22/27	IF32/27		
S30/27	G27/27	IF42/27		
	G32/27			
	G42/27			

S101

Soldering	Threated M	Threated F	Rotalock R	Grooved V
S6/27	C22/27	F22/27	R19/27	V32/27
S8/27	C27/27	F27/27	R25/27	V40/27
S12/27	C32/27	F32/27	R32/27	BV32
S14/27	C42/27	F42/27	R44/27	BV40
S16/27	IC22/27	IF6/27		
S18/27	IC27/27	IF8/27		
S19/27	IC32/27	IF22/27		
S22/27	IC42/27	IF27/27		
S28/27	G22/27	IF32/27		
S30/27	G27/27	IF42/27		
IS41	G32/27			
S42/27	G42/27			
S50/27				

S182/S182M/S202/S202M/S222

Soldering	Threated M	Threated F	Rotalock R	Grooved V	Flanges F
S6/38	C22/38	F22/38	R19/38	V32/38	CF66
S8/38	C27/38	F27/38	R25/38	V40/38	
S12/38	C32/38	F32/38	R32/38	V50/38	
S14/38	C42/38	F42/38	R44/38	V65/38	
S16/38	C48/38	F48/38	R58/38	BV32	
S18/38	C60/38	F60/38		BV40	
S19/38	IC22/38	IF6/38			
S22/38	IC27/38	IF8/38			
S28/38	IC32/38	IF22/38			
S30/38	IC42/38	IF27/38			
IS41	IC48/38	IF32/38			
S42/38	IC60/38	IF42/38			
S54/38	G22/38	IF48/38			
S60/38 *	G27/38	IF60/38			
	G32/38				
	G42/38				
	G48/38				
	G60/38				
	G70/38				

* NO S222

ALL POSSIBLE CONNECTIONS
FOR THESE CONNECTIONS CONTACT TECHNICAL DEPT

S404 / S424					
Soldering	Threated M	Threated F	Rotalock R	Grooved V	Flanges F
S6/38	C22/38	F22/38	R19/38	V32/38	CF65
S8/38	C27/38	F27/38	R25/38	V40/38	CF80
S12/38	C32/38	F32/38	R32/38	V50/38	NF65
S14/38	C42/38	F42/38	R44/38	V65/38	NF80
S16/38	C48/38	F48/38	R58/38	V80/38	
S18/38	C60/38	F60/38		V80L	
S19/38	C76/38	IF6/38		V90/38	
S22/38	C90/38	IF8/38		BV32	
S28/38	IC22/38	IF22/38		BV40	
S30/38	IC27/38	IF27/38			
IS41	IC32/38	IF32/38			
S42/38	IC42/38	IF42/38			
S54/38	IC48/38	IF48/38			
S64/38	IC60/38	IF60/38			
IS66	IC70/38	IF73/38			
S76/38	IC90/38				
IS80	G22/38				
S90/38	G27/38				
IS92	G32/38				
	G42/38				
	G48/38				
	G60/38				
	G76/38				
	G90/38				

S606/S606M					
Soldering	Threated M	Threated F	Rotalock R	Grooved V	Flanges F
S6/38	C22/38	F22/38	R19/38	V32/38	CF65
S8/38	C27/38	F27/38	R25/38	V40/38	CF80
S12/38	C32/38	F32/38	R32/38	V50/38	CF100
S14/38	C42/38	F42/38	R44/38	V65/38	NF65
S16/38	C48/38	F48/38	R58/38	V80/38	NF80
S18/38	C60/38	F60/38		V80L	NF100
S19/38	C76/38	IF6/38		V90/38	
S22/38	C90/38	IF8/38		V100	
S28/38	IC22/38	IF22/38		BV32	
S30/38	IC27/38	IF27/38		BV40	
IS41	IC32/38	IF32/38			
S42/38	IC42/38	IF42/38			
S54/38	IC48/38	IF48/38			
S64/38	IC60/38	IF60/38			
IS66	IC60/38	IF73/38			
S76/38	IC70/38				
IS80	IC90/38				
S90/38	IC100/38				
IS92	G22/38				
S100/38	G27/38				
IS102	G32/38				
	G42/38				
	G48/38				
	G60/38				
	G76/38				
	G90/38				
	G100/38				

S Soldering connections

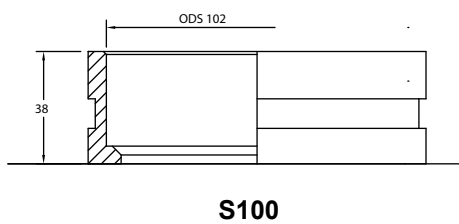
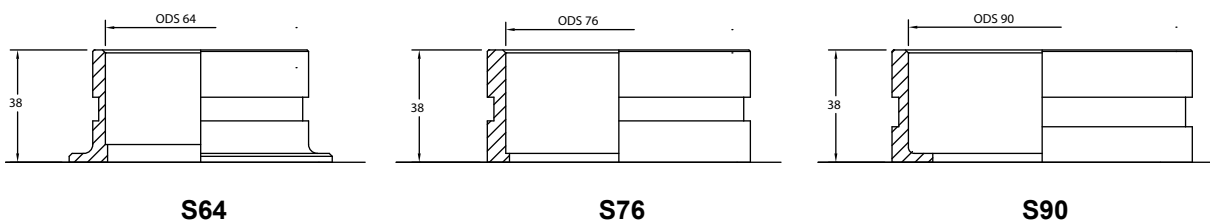
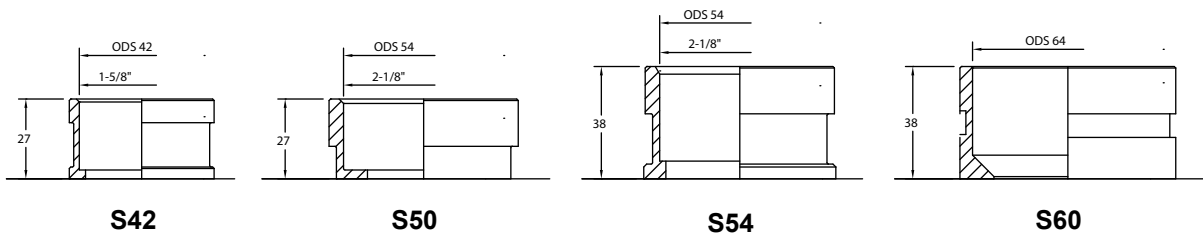
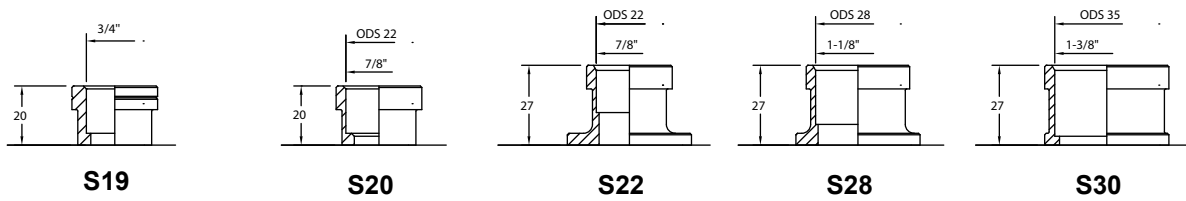
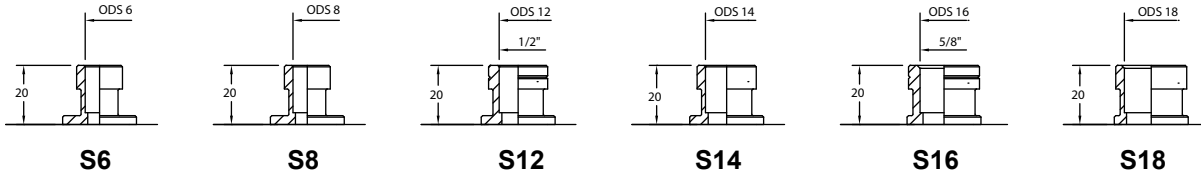

F Gas thread connections female

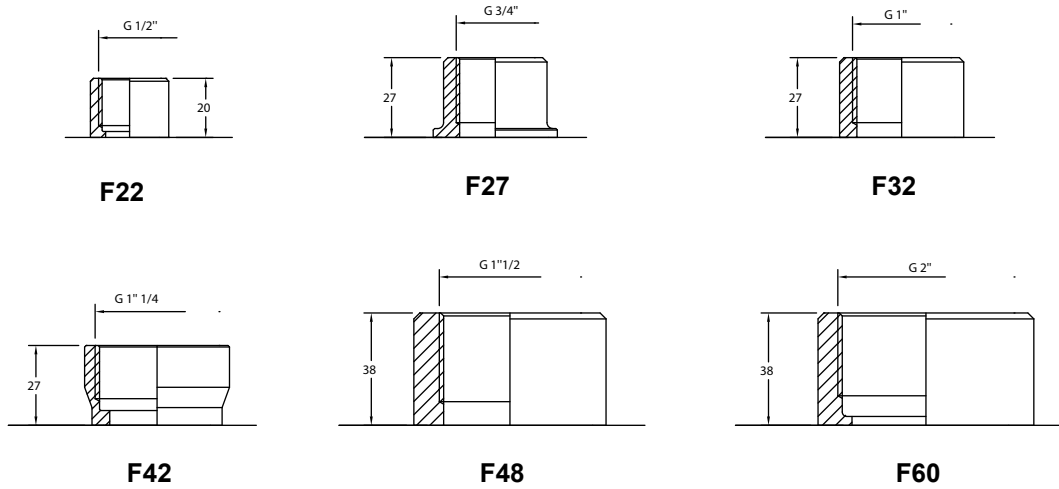

C Gas thread connections Male conical

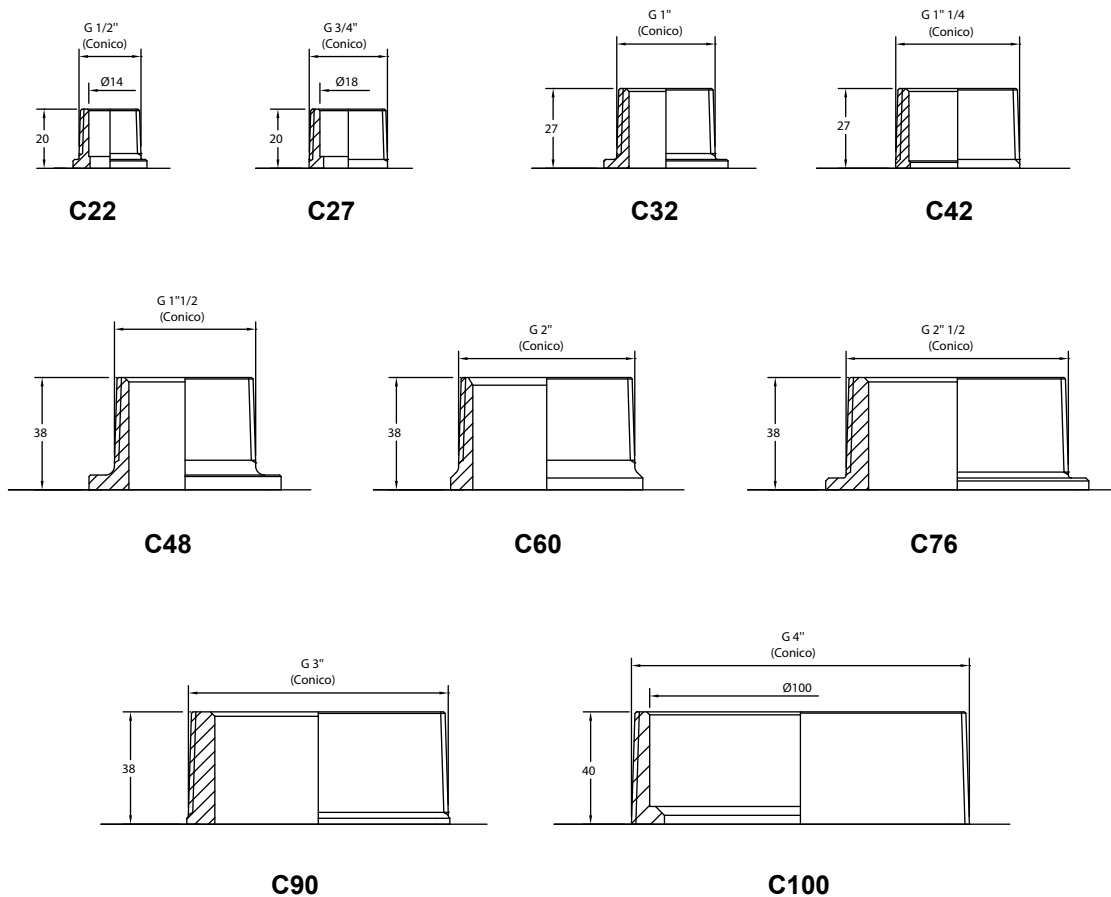

G Gas thread connections male cylindrical

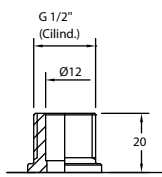

G22

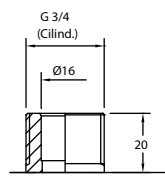

G27

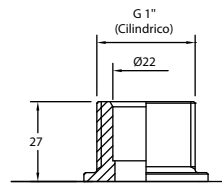

G32

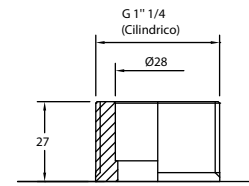

G42

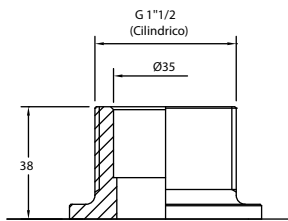

G48

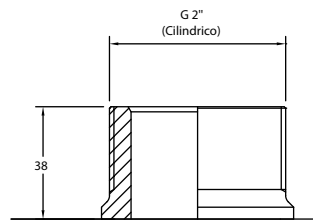

G60

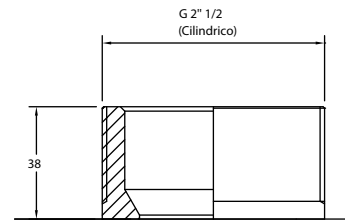

G70

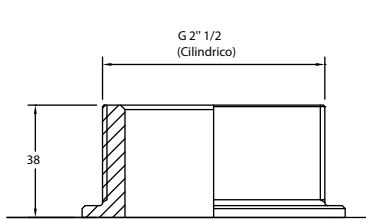

G76

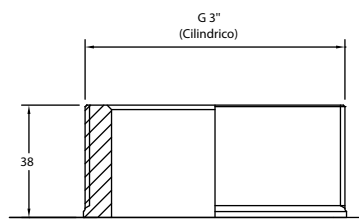

G90

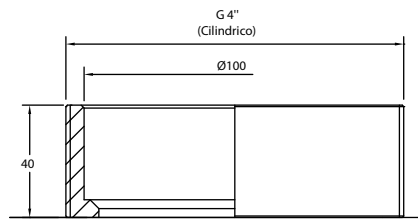

G100

R Rotalock connections Male

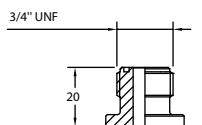

R19

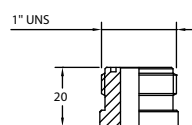

R25

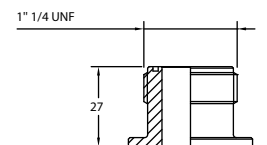

R32

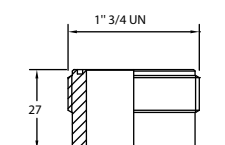

R44

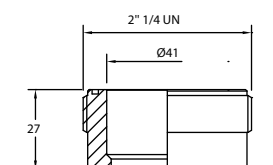

R58

V-BV Growed fittings

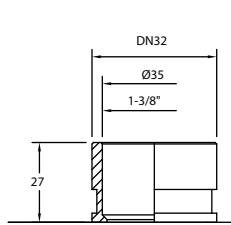

V32

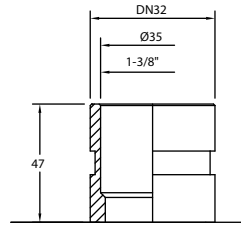

BV32

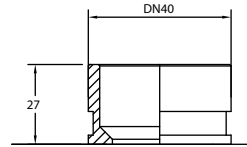

V40

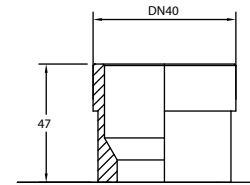

BV40

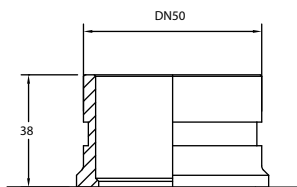

V50

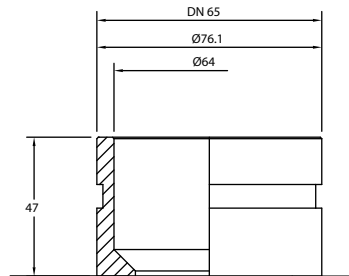

V65

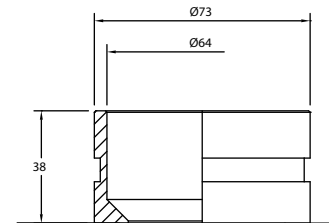

V72

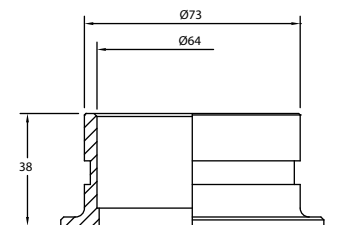

V73

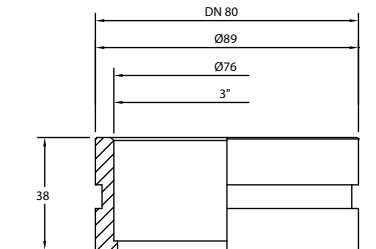

V80

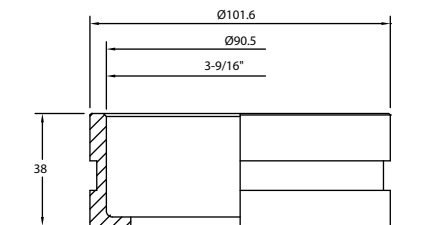

V90

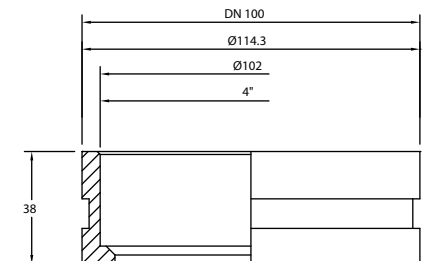

V100

CF Compact Flange

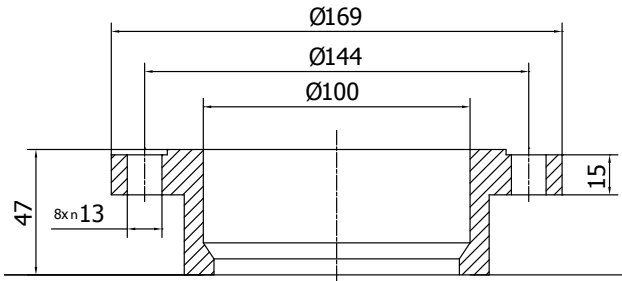

CF100

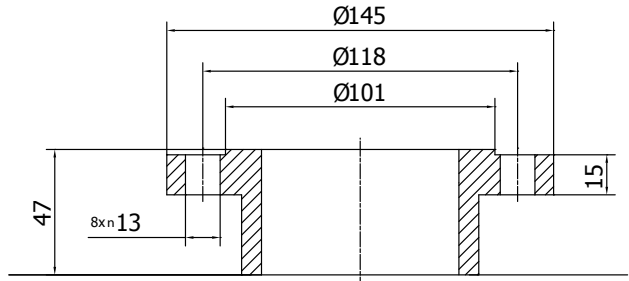

CF80

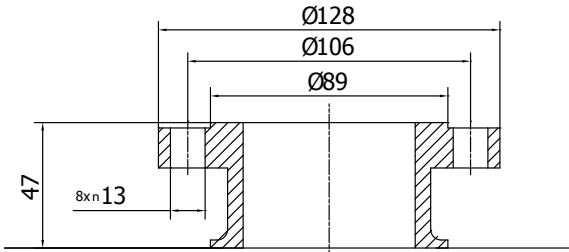

CF65

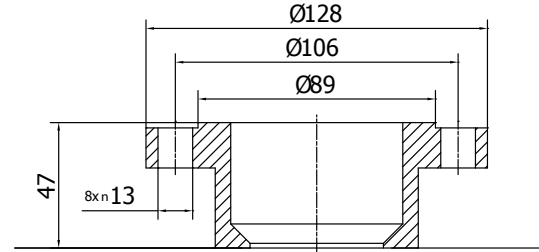

CF66

NF DIN Flange

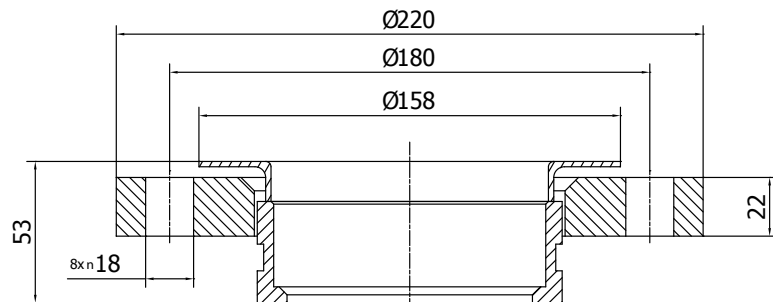

NF100

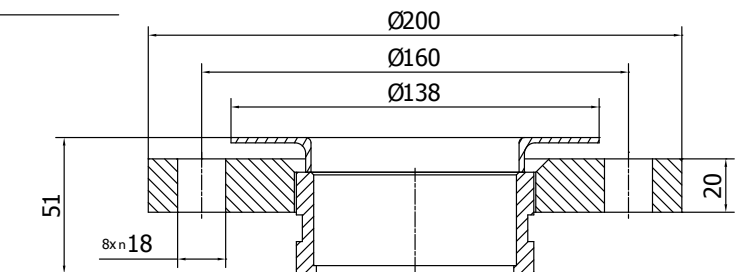

NF80

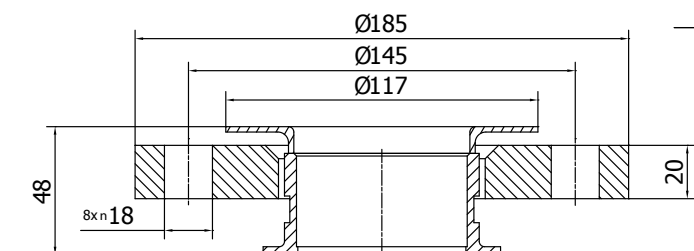

NF65

INCHES CONNECTIONS

S-IS Soldering connections

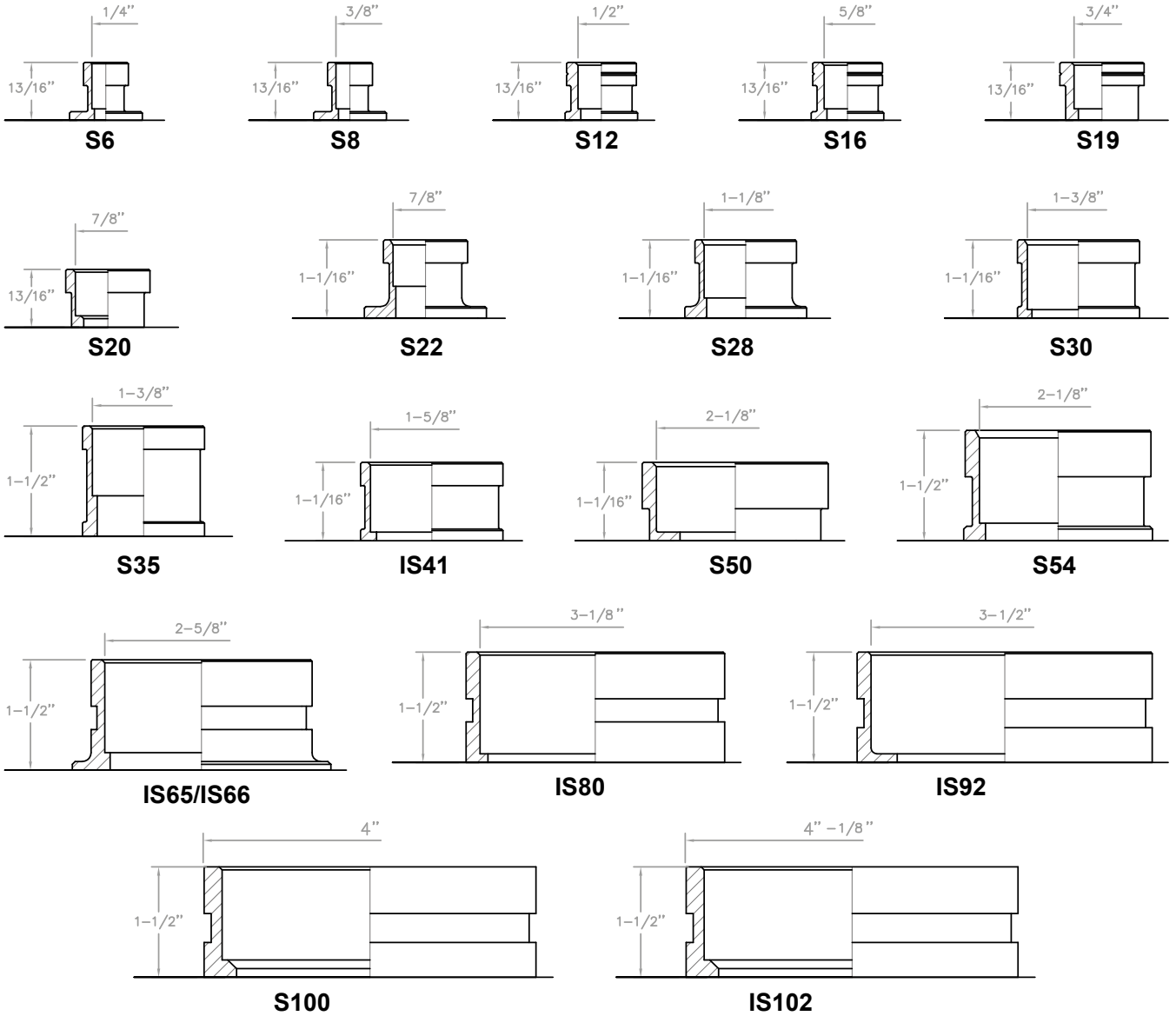

R Rotalock connections Male

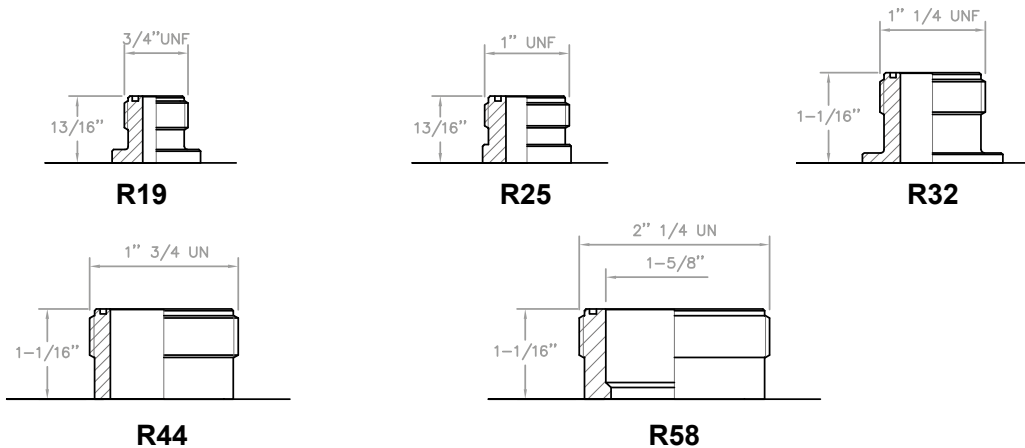

IC NPT Threaded connections Male

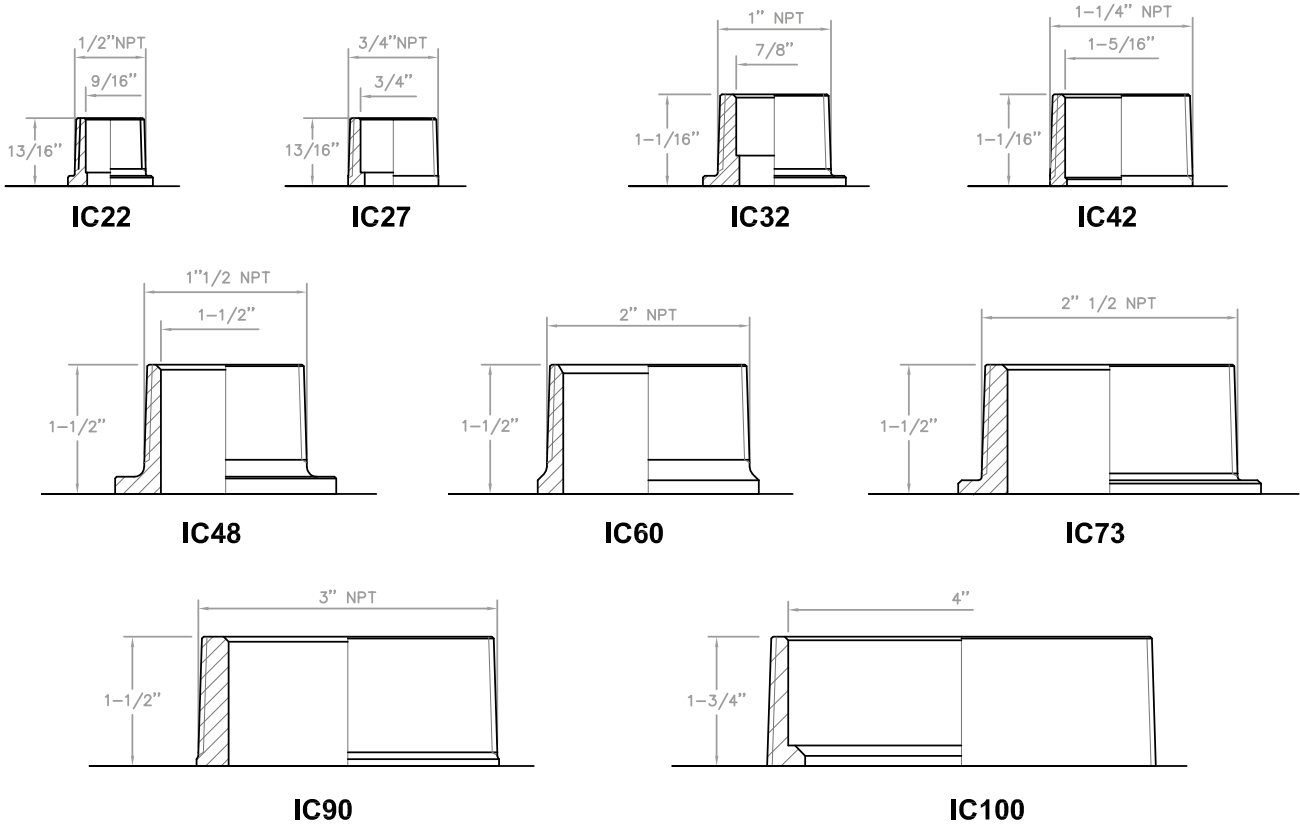

IF NPT Threaded connections Female

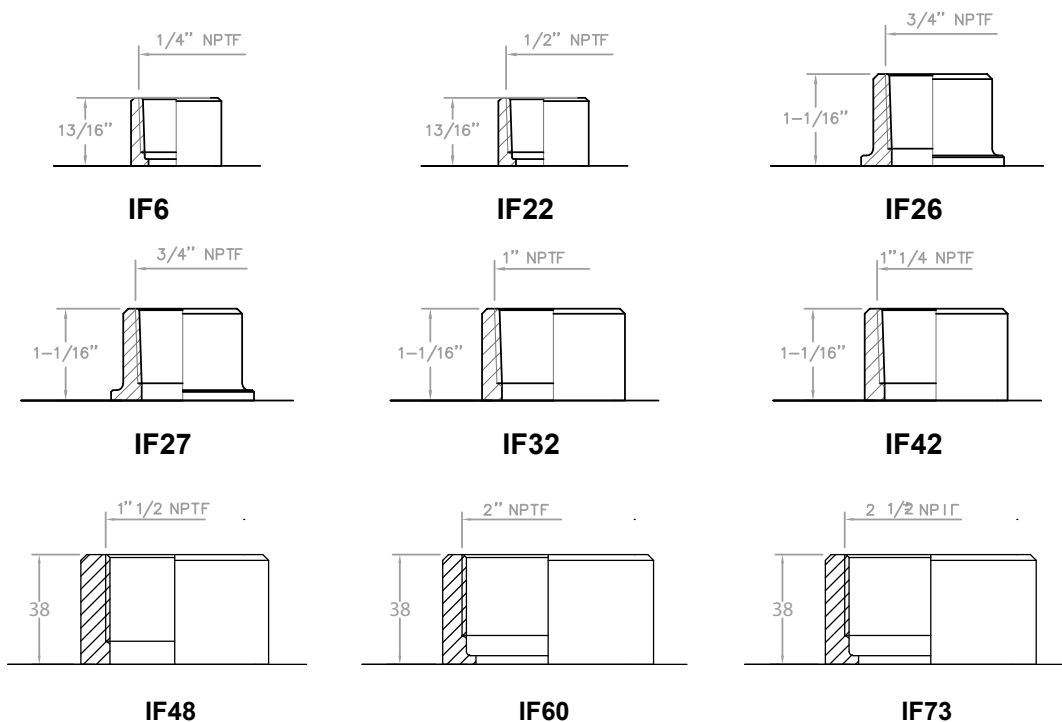

INCHES CONNECTIONS

V-BV Grooved fittings

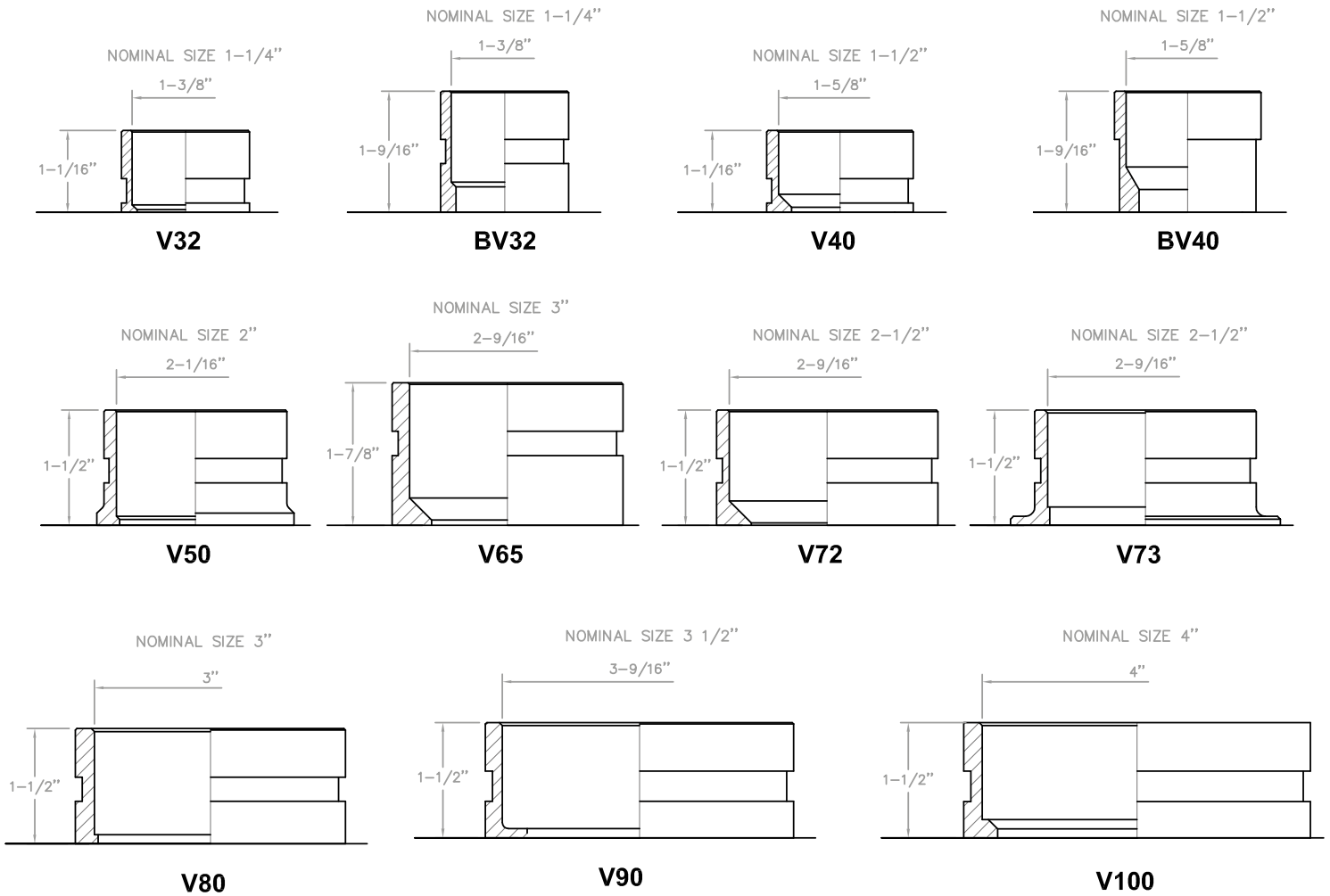

IN ANSI Lap Joint flanges 300 lb/sq.in.

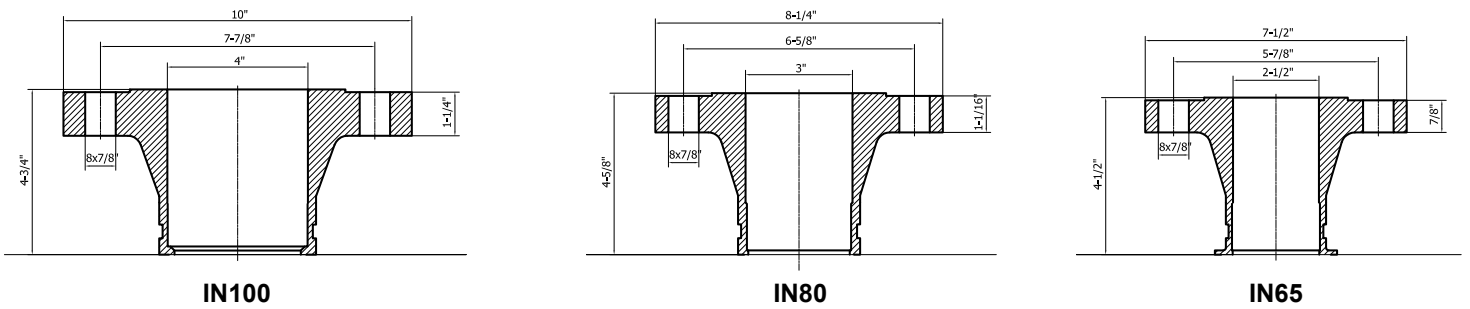

GARANZIA

A - Onda S.p.A. garantisce l'assenza di vizi e difetti nella lavorazione e nei materiali nei Prodotti per 18 mesi dalla data della consegna.

Pertanto ove, durante il periodo di garanzia, i contestati difetti dei Prodotti risultino oggettivamente fondati e siano riconosciuti per iscritto da Onda S.p.A., quest'ultima provvederà gratuitamente alla riparazione o, a sua discrezione, alla sostituzione dei Prodotti difettosi, con consegna effettuata franco fabbrica (Ex Works – Incoterms 2000) Stabilimento di Onda S.p.A. in Via Lord Baden Powell, 11 – 36045 Lonigo (VI).

B - Pena di decadenza dalla garanzia, il Cliente dovrà denunciare per iscritto, a mezzo raccomandata con ricevuta di ritorno, i vizi o i difetti riscontrati entro e non oltre 10 (dieci) giorni dal ricevimento dei Prodotti o evidenziati dalla messa in funzione dell'impianto, oppure, trattandosi di vizi e/o difetti occulti, entro e non oltre 10 (dieci) giorni dalla scoperta degli stessi. In questo caso, l'onere della prova della data della scoperta graverà sul Cliente.

C - Onda S.p.A. garantisce inoltre che i Prodotti sono fabbricati in conformità alle leggi italiane e alle normative comunitarie vigenti alla data di conferma da parte di Onda S.p.A. del relativo ordine del Cliente.

Salvo diverso accordo scritto tra le parti, tutte le altre spese accessorie agli interventi di sostituzione e/o di riparazione, saranno a carico e a rischio del Cliente.

D - La garanzia è esclusa qualora i vizi o difetti dei Prodotti siano stati determinati dalle seguenti cause:

- Naturale usura e deterioramento.
- Riparazioni, manomissioni o modifiche non autorizzate.
- Uso e applicazione impropri.
- Eccessiva sollecitazione termica, anche occasionale.
- Eccessiva sollecitazione elettrica o meccanica.
- Mancato rispetto dei parametri funzionali e ambientali indicati da Onda S.p.A. per il corretto impiego e funzionamento dei Prodotti.
- Installazione dei Prodotti difforme da quella indicate nelle specifiche tecniche fornite da Onda S.p.A.
- Mancata messa a terra dello scambiatore.
- Qualsiasi altra causa imputabile a negligenza del Cliente.

E - La garanzia è inoltre esclusa in caso di:

- Eventuale non conformità dei Prodotti a normative italiane e/o comunitarie entrate in vigore dopo la data della trasmissione della conferma d'ordine di Onda S.p.A.;
- Eventuale non conformità dei Prodotti a leggi e/o normative in vigore nel luogo in cui i Prodotti sono installati e/o assemblati dal Cliente e/o nel luogo di finale utilizzazione dei Prodotti, qualora il Cliente non abbia espressamente richiesto la conformità dei Prodotti a tali leggi e/o normative e non abbia regolarmente informato ONDA S.p.A. del loro contenuto prima della data di trasmissione della conferma d'ordine di quest'ultima. Resta inteso che la presente limitazione si intende efficace anche con riferimento a specifiche normative vigenti in Stati dell'Unione Europea ed applicabili in via autonoma rispetto alle normative comunitarie.

F - Il Cliente non dovrà vendere o commercializzare Prodotti non conformi alle leggi e/o normative indicate nella precedente lettera E. In caso contrario, il Cliente manleverà ONDA S.p.A. da ogni danno e/o perdita dalla stessa sofferto in seguito a contestazioni, sollevate in via giudiziale o stragiudiziale, da qualsiasi soggetto terzo o da pubblica autorità in conseguenza della fabbricazione da parte di ONDA S.p.A. di prodotti non conformi alle summenzionate leggi e/o normative.

G - Ferma restando l'applicazione del DPR 224/1988, in materia di responsabilità per danno da prodotti difettosi, e la responsabilità di Onda S.p.A. in caso di dolo o colpa grave, quest'ultima non sarà in alcun caso responsabile per i danni diretti, indiretti o incidentali che dovessero in qualsiasi modo derivare dalla difettosità dei Prodotti.

WARRANTY

A - Onda S.p.A. warrants that the Products shall be free from defects in material and workmanship for a period of 18 months from the date of the delivery.

Therefore, should Onda S.p.A., within the warranty period, acknowledge and recognise in writing the existence of the defects in the products and said defects be materially grounded, Onda S.p.A. shall, at its discretion, repair the defective Products at no costs for the Client or replace them by delivering the substitutive products Ex works (Incoterms 2000) at Onda S.p.A.'s premises (Via Lord Baden Powell, 11 – 36045 Lonigo (VI) – Italy).

B - Subject to loss of the warranty, notice of any defect shall be given by the Client in writing with return receipt registered letter within, and not later than, 10 (ten) days from the date of receipt of the products or from the start up of the plant. Subject to loss of the warranty, notice of any latent defect of the Products by the Client shall be given in writing, by return receipt registered letter, within and not later than 10 (ten) days from the date of the relevant discovery. It is hereby understood that the burden of the proof of the date of the discovery shall be borne by the Client.

C - Onda S.p.A. also warrants that the Products are manufactured in compliance with the Italian and European Laws and Regulations in force on the date of the confirmation by Onda S.p.A. of the relevant Client's order. Unless otherwise expressly agreed in writings by the parties, Client shall bear any other additional expenses related to the operations of repairing or replacing of the defective products.

D - This warranty shall not apply should the defects of the Products be caused by:

- Natural wear and tear.
- Unauthorised repairs, interventions or modifications.
- Unsuitable use or application.
- Thermal overexposure, also when occasional.
- Electrical or mechanical over-stress.
- Failure of respecting the functional and environmental parameters suggested by Onda S.p.A. for the correct use and exploitation of the products.
- Installation of the products not in compliance with the technical specifications provided by Onda S.p.A.
- Missing earth grounding.
- Any other cause due to the Client's negligence.

E - This warranty shall also not apply in case of:

- Non compliance of the Products with Italian and European Laws and/or Regulations entered in force after the date of transmission of the order confirmation by Onda S.p.A..
- Non compliance of the Products with Laws and/or Regulations in force in the place where the Products are installed and/or assembled by the Client and/or in the place of their final use, should the Client not expressly require the conformity of the Products to said Laws and Regulations and not duly inform Onda S.p.A. of their content before the date of transmission of the latter's order confirmation. This limitation of the warranty is also applicable with reference to peculiar Laws and Regulations valid and binding in States of the European Union independently of the European Laws and Regulations.

F - The Client shall not sell or market Products not in compliance with the Laws and Regulations mentioned under letter E above. In the negative, the Client shall keep ONDA S.p.A. harmless of any damage or loss suffered by the latter, due to any third party's and/or authority's claim raised as a consequence of the manufacture by ONDA S.p.A. of Products not in compliance with the above mentioned Laws and Regulations.

G - Without prejudice to the application of DPR 224/1988 on product liability and liability for gross negligence or wilful misconduct, Onda S.p.A. shall never be liable for direct, indirect or occasional damages which in any manner derived from defective products.



ONDA S.p.A.

Via Dante Alighieri, 27B 36065 Mussolente (VI) Italy t. +39 0424 87633 f. +39 0424 578667
Via Vittoria, 158A 36065 Mussolente (VI) Italy t. +39 0424 87506 f. +39 0424 87744
Via L. Baden Powell, 11 36045 Lonigo (VI) Italy t. +39 0444 720720 f. +39 0444 720721

Onda France S.A.R.L.

320, Avenue Berthelot
9008 Lyon France
t. +33 472784606
m. +33 608341000

Onda USA L.L.C.

600 London Rd
Delaware, OH 43015
t. +1 614 321 3342
f. +1 614 279 3668